

挤塑

EXTRUSION

ASIA EDITION

G 31239



1/2024

VM VERLAG
Cologne/Germany

Guill

WORLD LEADER IN EXTRUSION TOOLING

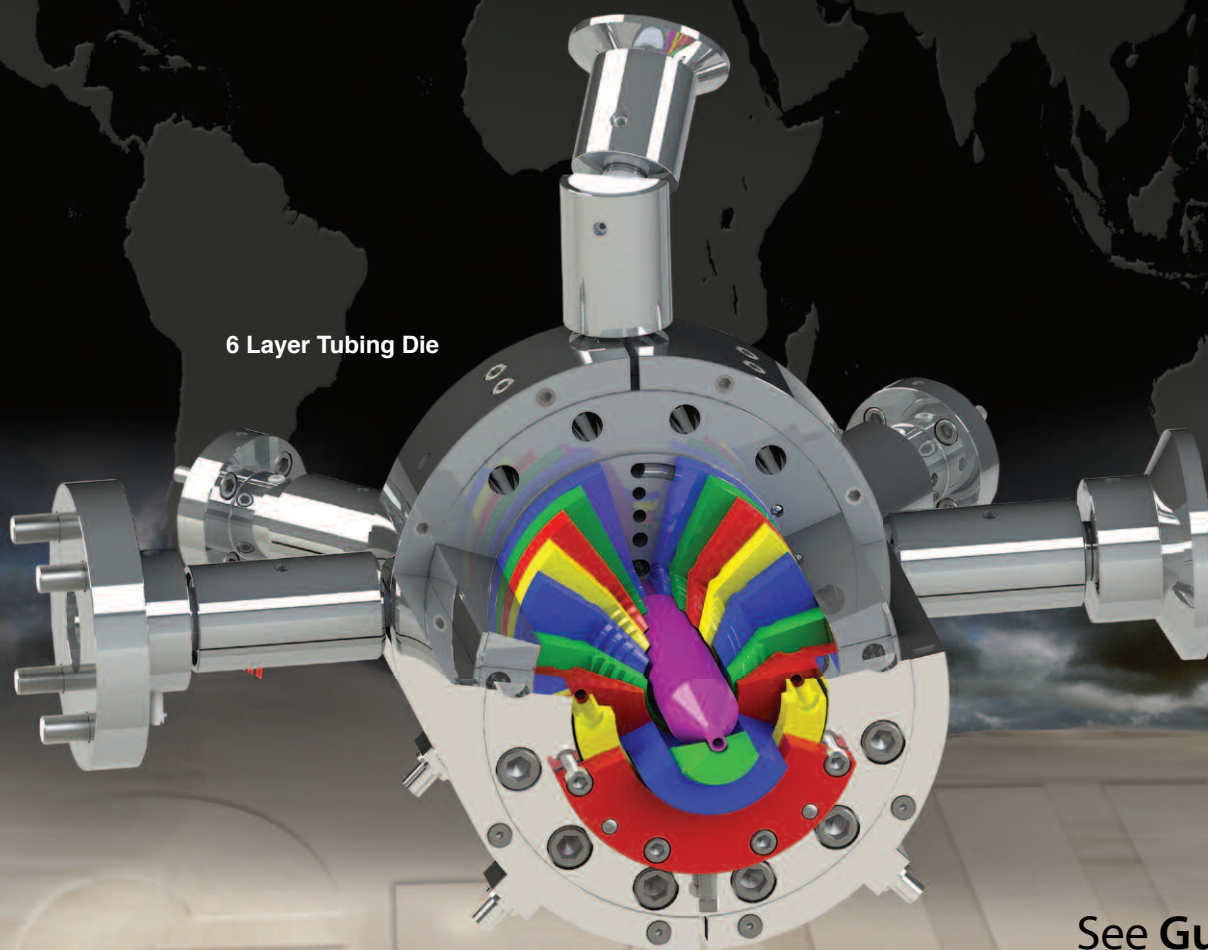

6 Layer Tubing Die

www.guill.com

See Guill at
NPE2024
The Plastics Show
Booth W7051

EXTRUSION

EXPERT MAGAZINE ON PLASTICS EXTRUSION

The only technical magazine worldwide exclusively for the sectors:

- Material Preparation
- Compounding
- Extrusion
- Recycling
- Calendering
- Thermoforming
- Welding
- Finishing of Plastics and Elastomers



Extrusion (German)

Extrusion International (English)

Extrusion International USA (English)

Extrusion Asia Edition (Mandarin/English)

The only plastics trade magazine for Asia, published from Germany

8 issues a year

6 issues a year

6 issues a year

2 issues a year

SMART
EXTRUSION

All editions available for free:

www.smart-extrusion.com

VA Verlag GmbH Cologne/Germany



标题 / Front page:
Guill Tool & Extrusion Co., Inc.
www.guill.com



- 03 内容 / Content
- 04 本期杂志中的公司目录 / 敬请垂询
Firms in this issue / Imprint
- 06 企业短讯 / Branche Intern
SWOP
K 2025
CITEX
PIXARGUS
KATUEX
JWELL
MAAG
Davis-Standard
BASF
SI Group
GINDUMAC
Clariant
Guill
Mylar
Orion
motan
Perstorp
- 22 挤压工具：挤压技术新发展
Extrusion Tooling: Extrusion Takes Some New Turns
- 26 挤出技术：制造ABS混合材料的新节能工艺
Extrusion Technology: New Energy-Efficient Process for Manufacturing ABS Blends
- 28 挤出薄膜：配有最新设计MDO单元的新型多功能流延薄膜生产线
Film Extrusion: Latest Version of Multi-Purpose Cast Film Line with New MDO Unit
- 30 平板薄膜挤出-案例研究：从转换加工到全系列供应商
Flat Film Extrusion – Case Study: From Converter to Full-Range Supplier
- 32 准备 - 面试：Pellet Vision
始终保持稳定的颗粒质量！
Processing – Interview: Pellet Vision – Constant Pellet Quality – Forever!
- 35 2024中国国际橡塑展：
期待已久，CHINAPLAS 时隔六年重返上海
业界对2024年国际橡塑展的预期不断上升
CHINAPLAS 2024: Long-awaited Return to Shanghai after Six Years Rising Expectations to CHINAPLAS 2024 from the Industry
- 38 经验与质量的完美结合
Experience Meets Quality
- 42 在 Chinaplas 2024 呈现创新的展台设计理念与多款亮点产品
With New Booth Concept and Several Product Highlights at Chinaplas 2024
- 44 OMNI回收机的新系列：创新的脱挥和去污技术，适用于现有和新兴的回收应用
New Range of OMNI Recycling Machines – Innovative Devolatilization and Decontamination Technologies for Existing and Emerging Recycling Applications
- 48 特种、功能性和可持续性薄膜的解决方案
Solutions for Special, Functional and Sustainable Films
- 50 扎根中国，服务中国：现有生产线的本土服务解决方案
Local Service Solutions for Existing Film Stretching Lines in China for China
- 52 Chinaplas 2024上重点展示本地产品
Local Production Highlighted at Chinaplas 2024
- 54 塑料混料和回收的先进技术
Pioneering Technologies for Plastics Compounding and Recycling
- 58 重点关注交通出行和自动化
Focus on Mobility and Automation

A dsale	35
Arburg	58
B ASF Plastic Additives.	14
Brückner Maschinenbau	48
Brückner Servtec	50
C HINAPLAS 2024	35
CITEX	08
Clariant.	17
Coperion	26, 54
Coperion K-Tron	54
D avis-Standard	12
E CON.	32, 41
EREMA	38
F IMIC.	13
G INDUMAC	16
Gneuß	44
Guill. 封面 / Front Cover, 18,	22
H erbold Meckesheim	54
J well.	10
K 2025.	08
Kautex	10
M AAG	12, 52
Messe Düsseldorf	08
motan.	18
Mylar	19
O Orion	20
P erstorp	21
Pixargus	08
P lasMec	09
R eifenhäuser	30
S I Group	15
S ikora	19, 42
Smart-Extrusion Inside Back Cover, 41, 47,	
. Outside Back Cover	
S ML	07, 28
SWOP 2023	06
V M Verlag Inside Fron Cover, 34	
Z umbach.	11



VM 出版社有限公司 / VM Verlag GmbH:
Krummer Büchel 12, D-50676 Köln, Cologne, Germany

VM 出版社有限公司 / 编辑+出版
VM Verlag GmbH – Editorial Office + Layout:
P.O. BOX 50 18 12, D-50978 Cologne, Germany
Bettina Jopp-Witt M.A.
(Editor-in-Chief EXTRUSION, EXTRUSION International,
EXTRUSION Asia Edition)
T.: +49 221 546 15 39, Fax: +49 221 168 60 13
email: b.jopp-witt@vm-verlag.com, redaktion@vm-verlag.com

VM 出版社有限公司 / 广告与销售
VM Verlag GmbH – Sales + Distribution:
P.O. BOX 50 18 12, D-50978 Cologne, Germany
Dipl.-Ing. Alla Kravets (Administration)
T.: +49 2233 9498793, Fax: +49 2233 9498792
e-mail: a.kravets@vm-verlag.com
Martina Lerner (Sales)
T.: +49 6226 97 15 15, e-mail: lerner-media@t-online.de
Bella Eidlin (Sales)
T.: +49 15229907895, e-mail: b.eidlin@vm-verlag.com
Tanja Bolta (Sales)
T.: +49 15205626122, e-mail: t.bolta@vm-verlag.com

第28出版年 – 出版次数：每年2期
28. Volume – Frequency: 2 issues a year



全球代理 / Representatives:





26 科倍隆 (Coperion) 为丙烯腈-丁二烯-苯乙烯共聚物(ABS)共混物料的特别节能制造开发出了一种工艺解决方案，科倍隆 ZSK Mc18双螺杆挤出机发挥了关键的核心作用。
Coperion has developed a process solution for particularly energy-efficient manufacturing of acrylonitrile-butadiene-styrene copolymer (ABS) blends, with the Coperion ZSK Mc18 twin screw extruder playing a key central role.



44 在 2024 年中国国际橡塑展上, SIKORA 将展示其一系列新产品, 用于软管和管材挤出及材料生产和加工中的质量控制和成本优化。软管和管材挤出以及材料生产和加工中的质量控制和成本优化。
At Chinaplas 2024 SIKORA, will be demonstrating its range of current, improved and new products for quality control and cost optimization in hose and tube extrusion and material production and processing.

SML在其技术中心安装一条新型多功能流延薄膜生产线。该生产线的通用性好，拥有多项技术创新，其中最为重要的是经进。
SML has set up the newest version of its multi-purpose cast film line in its Technology Centre. The line is universally applicable and features a number of technical innovations.

提到高效安全地处理聚酯PET废料，毫无疑问EREMA拥有宝贵的经验。
When it comes to the efficient and safe processing of PET waste, EREMA can draw on valuable experience.



28



38

在上海举行的 2024 年中国国际橡塑展上，布鲁克纳公司将重点放在全球需求量巨大的特种薄膜制造上，特别是在快速增长的电动汽车和新能源领域。
48 *At Chinaplas 2024 in Shanghai, Brückner's clear focus is on the manufacturing of specialty films which are in great demand worldwide, especially for the rapidly growing e-mobility and new energy sector.*

在 2024 年中国国际橡塑展上，布吕克纳服务技术 (Brückner Servtec) 展示了全新的本地化服务解决方案，如审计、增强备件库存以及经认证的夹具和链条翻新，以提高现有薄膜拉伸生产线的可用性，实现“在中国，为中国”的口号。
50 *At Chinaplas 2024, Brückner Servtec presents brand new local service solutions such as audits, enhanced spare parts stocks and certified clip and chain refurbishment to increase the availability of existing film stretching lines according to the motto "in China for China".*

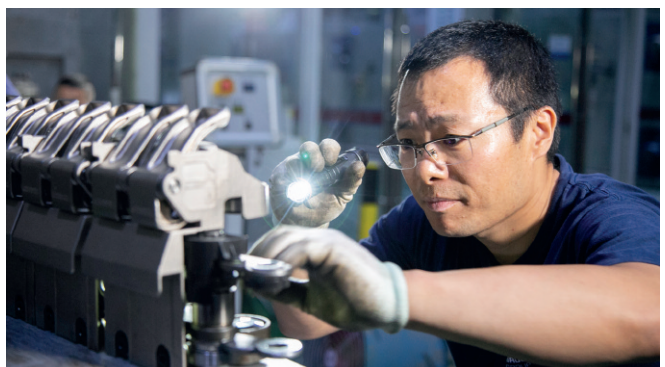



CHINAPLAS 2024

23 - 26 April 2024

Shanghai / PR China

山海关 / 中國

➡ www.ChinaplasOnline.com

NPE2024

06 - 10 May 2024

Orlando, Florida / USA

佛罗里达州, 奥兰多 / 美利坚合众国

➡ <https://npe.org/>

Plastpol

21 - 23 May 2024

Kielce / Poland

基尔采 / 波兰

➡ www.targkielce.pl/en/plastpol/

AP-RubberPlas

10 - 13 July 2024

Qingdao / PR China

青岛 / 中國

➡ <https://en.ap-rubberplas.com/>

Fachpack

24 - 26 September 2024

Nuremberg / Germany

伦堡 / 德国

➡ www.fachpack.de/

Tube China

25 - 28 September 2024

Shanghai / PR China

山海关 / 中國

➡ www.tubechina.net/

Fakuma 2024

15 - 19 October 2024

Friedrichshafen / Germany

弗里德里希港 / 德国

➡ www.fakuma-messe.de/

Film & Tape Expo

06 - 08 November 2024

Shenzhen / PR China

深圳 / 中國

➡ www.film-expo.com/

DMP

26 - 29 November 2024

Shenzhen / PR China

深圳 / 中國

➡ www.dmpsz.com

包装世界博览会 (swop) 2023成功结束 , 并为接下来的年度展铺平了道路

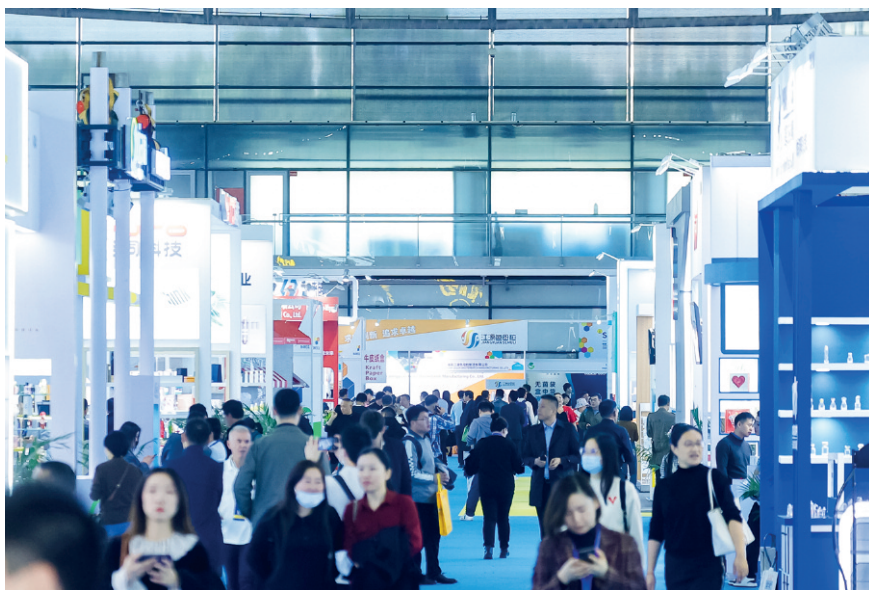

■ 作为世界领先的德国杜塞尔多夫国际包装展览会联盟成员,也是包装行业最具影响力的活动之一,swop 包装世界上海博览会 2023于11月22日至24日在上海新国际博览中心(SNIEC)成功举办。

上海国际展览中心包装世界博览会 (swop) 2023由杜塞尔多夫由国际展览集团有限公司(Messe Düsseldorf)和雅式展览服务公司 (Adsale) 联合主办。为期三天的展会吸引了来自世界各地的行业领袖、专业人士和观众,讨论加工和包装行业的最新技术和发展。

近3万名业内人士参加了此次活动,这标志着经过4年的筹备,活动取得了积极的回报swop 2023展览面积超过62000平方米,吸引了近900家国内外参展商,接待了来自99个国家和地区的3万名专业观众。在为期三天的活动中,观众人数比上届增加了14%。

swop 2023获得了来自食品、日化、塑料、印刷、包装等100多个国内外行业协会的广泛支持,接待了来自中国、东南亚、中东、南美和欧洲的近300个代表团。

德国杜塞尔多夫展览集团公司的国际包装机械 (interpack) 总监Thomas Dohse说:“我很高兴看到swop作为国际包装机械联盟的成员,在展览空间、参展商和观众人数方面都创下了新的记录。我们很高兴与参展商和观众面对面地见面,他们在缺席4年后终于回到了swop。”

swop 2023围绕可持续包装和低碳发展,推出了“绿色动力区”的新主

题。150多家参展商展示了各种环保包装材料、生产设备和解决方案,以支持包装公司和品牌实现可持续发展目标。

swop 2023推出“智能包装区”,展示众多智能塑料和纸包装容器、包装机和后端包装设备。这些产品完全满足智能化要求,使其能够提高效率和降低成本展会期间,举办了10余场行业论坛、新技术交流会、60余场专题讨论,参会人数1820人,座无虚席。邀请专家、学者、企业领导对包装行业的热门话题进行全面深入的论述和分析。其中一个亮点是“拯救粮食论坛”。“节约粮食”是由联合国粮食及农业组织(FAO)、联合国环境规划署(UNEP)、杜塞尔多夫展览中心和interpack共同发起的全球倡议。它旨在促进创新,促进跨学科对话,发起讨论,减少全球粮食浪费和损失,为应对全球粮食损失作出贡献。

第三届节约粮食中国论坛邀请了来自多个机构和企业的专家、学者和代表。

第三届节约粮食中国论坛首次在swop向参展商颁发“节约食品设计奖”和“可持续设计大奖”。表彰最大限度减少食物浪费的创新产品,而“可持续设计大奖”则赞扬具有积极环境影响的解决方案,如减少CO₂足迹。联合国工业发展组织、世界包装组织和粮农组织担任评委委员会成员,对申请公司进行评价。

本次展会的圆满结束,标志着包装行业的又一个里程碑。swop将每年举办一次,下一届定于2024年11月18日至20日在上海新国际博览中心举行。

swop 2023 Successfully Concludes and Paves the Way for Annual Edition

■ As a member of the interpack alliance, the world's leading processing and packaging exhibition, and as one of the most influential events in the packaging industry, swop (Shanghai World of Packaging) 2023 was successfully held at SNIEC (Shanghai New International Expo Center) from November 22 to 24.

swop is co-organized by Messe Düsseldorf (Shanghai) and Adsale Exhibition Services. The three-day exhibition attracted industry leaders, professionals, and visitors from all over the world to discuss the latest technologies and developments in the processing and packaging industry. Close to 30,000 trade visitors attended the event, which marked a positive return after 4 years' preparation.

With an exhibition area of over 62,000 square meters, swop 2023 attracted nearly 900 domestic and foreign exhibitors and welcomed 30,000 professional visitors from 99 countries and regions. The three-day event showcased a remarkable 14% increase in visitors compared to the previous edition.

swop has garnered extensive support from over 100 domestic and international industry associations in food, daily chemicals, plastics, printing, packaging, etc. swop 2023 welcomed nearly 300 visitor groups from China, Southeast Asian countries, the Middle East, South America and Europe.

Thomas Dohse, Director of interpack at Messe Düsseldorf GmbH, said, "I am pleased to see that swop, as a member of the interpack alliance, has reached a new record with exhibition space and exhibitor and visitor numbers. We were excited to meet face-to-face with exhibitors and visitors who were finally back to swop after a 4-year absence."

Focusing on sustainable packaging and low-carbon development, swop 2023 introduced a new theme – "Green Power Zone". Over 150 exhibitors displayed diverse eco-friendly packaging materials, production equipment, and solutions to support packaging companies and brands in achieving sustainable development objectives.

swop 2023 launched the "Smart Packaging Zone" to display numerous intelligent plastic and paper packaging containers, packaging machines, and back-end packaging equipment. These products fully meet requirements for intelligence, enabling them to enhance efficiency and reduce costs.

During the show, more than 10 industry forums, new technology exchange sessions, and over 60 thematic discussions were all fully packed with 1,820 participants. Experts, scholars, and corporate leaders were invited to engage in comprehensive and in-depth discourse and analysis of the trendy topics in the packaging industry. Among the highlights was the SAVE FOOD Forum. "SAVE FOOD" is a global initiative jointly launched by the Food and Agriculture Organi-

zation of the United Nations (FAO), the United Nations Environment Programme (UNEP), Messe Düsseldorf, and interpack. It aims to promote innovation, foster cross-disciplinary dialogue, initiate discussions, and reduce global food waste and loss to contribute to the fight against global food loss.

The 3rd SAVE FOOD China Forum invited experts, scholars and representatives from several organizations and companies.

For the first time, the SAVE FOOD Initiative presented the SAVE FOOD DESIGN AWARD and SUSTAINABILITY DESIGN AWARD to exhibitors at swop. The SAVE FOOD DESIGN AWARD acknowledged innovative products that minimize food waste, while the SUSTAINABILITY DESIGN AWARD celebrated solutions with positive environmental impacts, such as reducing CO² footprints. UNIDO, The World Packaging Organization (WPO), and FAO served as jury members for evaluating the applicant companies.

The successful conclusion of the exhibition marks another milestone in the packaging industry. swop will be held annually, and the next edition is scheduled at SNIEC (Shanghai New International Expo Centre) from November 18 to 20, 2024.

➔ www.swop-online.com

普遍适用 – 针对您的需求进行优化

无论您是生产金属化标准食品和非食品包装，还是易于回收的 MOPE 薄膜自立袋或工业产品，SML 的流延薄膜生产线始终针对您的特定要求进行优化。

Extrusion lines.
Engineered to perform.



SML
EXTRUSION LINES – ENGINEERED TO PERFORM ▶

了解更多关于
SML 流延薄膜生产线的信息

www.sml.at

K 2025 – 杜塞尔多夫会展中心邀请参展商

■ “又到了K展时间”- 所有打算参加K 2025的公司都可以在杜塞尔多夫看到。2025年10月8日至15日，国际塑料和橡胶工业将在其最重要的国际贸易博览会上再次会面。注册文件现已提供。对于所有希望参加2025K展的公司，注册的最后期限是2024年5月31日。

在这个领先的贸易博览会上展出的产品包括机械和设备、原材料和辅助产品以及半成品、技术零部件和增强塑料产品。此外，K 2025不仅是行业的业绩晴雨表及其全球创新市场，而且还提供方向，设定可持续的经济动力，并呈现前瞻性趋势。

杜塞尔多夫的K 2025目标定位于气候保护、数字化和循环经济的重大主题。K 2022已经成功地在这些领域发表了强有力的声明，提出了将在2025年实现下一个水平的可持续解决方案。

在即将到来的K展上，参展商将展示塑料和橡胶的负责任和价值驱动处理的进一步创新，并标志着允许在闭环系统中管理塑料的新途径。

在杜塞尔多夫K展的USPs不仅包括来自世界各地的公司展示的广泛产品线，而且还包括其附属活动的质量和多样性，除了由欧洲塑料协会和杜塞尔多夫会展中心组织的官方特别活动外，还包括橡胶街、科学校园和创业区。

K 2025的注册文件可在 www.k-online.com/2330 下载。

已经在2022年展出的公司可以使用之前的访问数据登录和注册。首次参展商将被引导一步一步通过注册过程。

K 2025 –

Messe Düsseldorf Invites Exhibitors

■ “It's K time again” – for all the companies intending to participate in K 2025 in Düsseldorf. From **8 to 15 October 2025** the international plastics and rubber industry will again meet at its most important international trade fair. Registration documents are now available. For all companies wishing to take part in K 2025, the **deadline for registrations is 31 May 2024**.

The ranges on display at this the leading

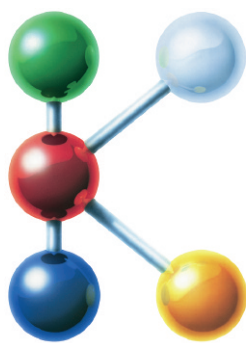

2025
8-15 OCTOBER
Düsseldorf, Germany

trade fair comprise the segments machinery and equipment, raw materials and auxiliaries as well as semi-finished products, technical parts and reinforced plastic products. What's more: K 2025 is not only the industry's performance barometer and its global marketplace for innovations but also provides orientation, sets sustainable economic impulses and present forward-looking trends.

K 2025 in Düsseldorf addresses the mega themes climate protection, digitalisation and circular economy. K 2022 already succeeded in making a powerful statement in these fields presenting sustainable solutions that will be taken to the next level in 2025. Exhibitors at the forthcoming K will showcase further innovations for the responsible and value-driven handling of plastics and rubber as well as flag up new avenues that allow plastics to be managed in closed-loop systems.

The USPs of K in Düsseldorf include not only its extensive line-up of ranges exhibited by companies from all over the world but also the quality and variety of its side events including – in addition to the official Special organised by Plastics Europe and Messe Düsseldorf – the Specials Rubber Street, Science Campus and the Start-up Zone.

Registration documents for K 2025 can be downloaded at:

www.k-online.com/2330

Companies that already exhibited in 2022 can log in and register using their previous access data. First-time exhibitors are guided through the registration process step by step.

➔ Messe Düsseldorf
www.k-online.de

收购

■ CiTEX Holding GmbH (CiTEX控股有限公司) 宣布收购总部位于德国Würselen的PIXARGUS。20年来，这家专业的技术公司一直为挤出产品提供在线质量控制，使用独特的图像处理技术来检测和记录产品缺陷和材料变化，作为塑料、金属、纸张和纤维复合材料制成的型材、软管、管道、电缆和板材的自动化表面检测以及几何测量的一部分，主要向欧洲的中型客户提供。

该收购突显了CiTEX控股致力于通过其子公司iNOEX巩固其作为全球领先的传感器及测量技术方面先进的数字化解决方案供应商的地位，并将自己定位为全球塑料挤出市场的领先供应商。

CiTEX 控股有限公司联合首席执行官 Ralph Klose 博士说道：“我们很高兴能够为我们的全球客户使用PIXARGUS的专业知识，特别是在美国、中国和亚洲的增长潜力方面。由于PIXARGUS的专业能力，我们的集团公司将有可能在未来全面设法解决我们在挤出技术方面全球客户群的需求。此外，此次收购不仅将使我们能够增加我们在关键市场的市场份额，而且我们还能够将利用丰富的数据和知识，作为我们数据科学活动的一部分。PIXARGUS在产品开发和咨询方面有着深厚的知识，特别是在汽车和型材市场领域。我们将在未来共同向客户提供整套自动化周期的全面支持。”

“CiTEX集团在过去40年里的业务发展反映了它在传感器/测量技术领域以及在挤出技术中更先进的数据处理领域受到客户和供应商的尊重。CiTEX的子公司iNOEX为中小企业和部门带来的全面专业知识是PIXARGUS及其行动的重要资产。我们共同专注于利用云解决方案促进数字化转型，使我们成为该细分市场的全面解决方案提供商。两家公司的合并也加强了我们的计划中的全球扩张。”

“我们都期待着与CiTEX集团的新同事一起踏上这段旅程。”PIXARGUS的董事总经理René Beaujean和Jürgen Phillips博士强调指出。

Acquisition

■ CiTEX Holding GmbH announced the acquisition of PIXARGUS, based in Würselen, Germany. The technically specialised company has been offering inline quality control for extrusion products for 20 years, using unique image processing

technology to detect and document flaws and material changes as part of automated surface inspection and geometry measurement of profiles, hoses, pipes, cables, and sheets made of plastic, metal, paper, and fibre composites, primarily for medium-sized customers in Europe. The acquisition underlines CiTEX Holding's commitment to consolidating its position as a leading provider of sensor and measurement technology and advanced digitalisation solutions worldwide, through its subsidiary iNOEX, and to distinguishing itself as a leading provider in the global plastics extrusion market.

"We are delighted to be able to utilise the expertise of PIXARGUS for our global customers, particularly with regard to the growth potential in the USA, China and Asia. Thanks to PIXARGUS' specialist competence, it will be possible for our group of companies to comprehensively address our global customer base in extrusion technology in the future. In addition, the acquisition will not only enable us to increase our market share in our key markets, but we will also be able to draw on a wealth of data and knowledge as

part of our data science activities," says Dr. Ralph Klose, CO-CEO of CiTEX Holding GmbH. "PIXARGUS has profound knowledge of product development and consulting, particularly in the automotive and profiles market segments. Together, we will be able to provide our customers with comprehensive support across the entire automation cycle in the future."

"The business development of the CiTEX Group over the last four decades reflects the esteem in which it is held by both customers and suppliers in the field of sensor/measurement technology and also in the more advanced segment of data processing in extrusion technology. The comprehensive expertise that CiTEX subsidiary iNOEX brings to the SME sector is a significant asset for PIXARGUS and its activities. Our joint focus on promoting digital transformation using cloud solutions makes us a comprehensive solution provider in this market segment. The merger of the two companies also strengthens our planned global expansion."

"We are all looking forward to embarking on this journey together with our new colleagues in the CiTEX Group," emphas-



Dr. Ralph Klose (CiTEX 控股有限公司联合首席执行官)

*Dr. Ralph Klose
(CO-CEO CiTEX Holding GmbH)*

side Managing Directors René Beaujean and Dr. Jürgen Philipps of PIXARGUS.

- ➔ CiTEX Holding GmbH
www.citex-group.de
- ➔ iNOEX GmbH
www.inoex.de
- ➔ PIXARGUS GmbH
www.pixargus.de

"ENSŌ" IN MIXING

looking for perfection



in equipment manufacturing for

PVC DRY-BLEND, MASTER BATCH, THERMOPLASTIC RUBBER, POWDER COATINGS, METALLIC BONDING and WPC



Visit us!
Hall 2.1 - Stand C97

PVC AUS 2024 Vinyl Council Australia
FUTURE DRIVEN THE ONLY CONFERENCE THAT BRINGS TOGETHER AUSTRALASIA'S VINYL CHAIN TO MEET, EDUCATE AND INNOVATE.
SAVE THE DATE 4-6TH JUNE 2024 HILTON, SURFERS PARADISE, QUEENSLAND

plasmec
Excellence in Mixing

PLAS MEC S.R.L.
Via Europa 79, 21015 Lonate Pozzolo (VA) - Italy
phone +39 0331 301648 - comm@plasmec.it
www.plasmec.it

新投资

■ 考特斯机械有限公司 (Kautex Maschinenbau GmbH) 及相关实体均已出售给金纬 (Jwell)，但考特斯顺德实体除外，此交易指日可待。考特斯机械有限公司的所有重大资产及全部业务运营已转让给中国投资者。2024年1月1日，新公司-考特斯机械系统有限公司 (Kautex Maschinenbau System GmbH) 接管了老公司的所有职责。

考特斯集团首席执行官 Thomas Hartkämper 表示说：“除了考特斯机械系统有限公司外，金纬是我们新的强大合作伙伴，我们有一个光明的未来。金纬在战略上适合我们。他们在塑料机械制造方面有很强的背景。他们有财力完成考特斯的转型，并致力于扩大我们在当地的制造和服务范围，目标是创造挤出吹塑中空成型业务的世界市场领导者”金纬接管了考特斯机械有限公司在波恩 50% 的员工，以及在其他实体的 100% 员工，并打算继续专注于波恩工厂的生产解决方案，该工厂仍然是专注于制造、研发和服务的总部。此外，位于波恩的考特斯机械有限公司将成为金纬的第三个海外生产基地。

对于那些没有被转移到新公司的员工，公司设立了一个转移公司，以进一步使他们有资格获得新的外部工作机会。这个机会受到了良好的接受，95% 的员工利用这个机会在职业生涯中取得了进步。

考特斯仍然是金纬集团内部的独立运营公司，并预期成为其高端品牌。随着转移到一家新公司，并对员工合适的规模进行了适当调整，管理层已经进行



了首次调整。考特斯前首席财务官兼首席人力资源官 Julia Keller 离开该公司，由雷军 (Jun Lei) 接任首席财务官。截至 2023 年 12 月底之前，Maurice Mielke 一直是考特斯的全球研发总监，晋升为首席技术官和首席人力资源官。考特斯集团前首席技术官 Paulo Gomes 决定于 2 月 1 日离开公司。

金纬总裁何先生对全体员工在过去一个月里的专注和敬业工作表示了最高的感谢，使得这笔交易成为现实。他表示，所有这些共同实现了他多年就有的梦想，在德国经营实体企业，带领金纬成为高端挤出机械行业的世界领导者之一。

New Investor

■ All Kautex Maschinenbau GmbH and related entities have been sold to Jwell, except the Kautex Shunde entity, on which a deal is within eyesight. All material assets and the entire business operations of the mechanical engineering company have been transferred to the Chinese investor. On January 1st, 2024, the new company – Kautex Maschinenbau System GmbH – took over all duties of the old company.

“With Jwell as new strong partner aside from Kautex Maschinenbau System GmbH, we have a bright future ahead. Jwell is a strategic fit for us. They have a strong background in plastics machinery manufacturing. They have the financial capabilities to complete Kautex transformation and they are committed to even increase our local manufacturing and service footprint with the target of creating the world market leader within the extrusion blow molding business”, states Thomas Hartkämper, CEO of the Kautex Group.

Jwell took over 50% of employees of Kautex Maschinenbau GmbH in Bonn, 100% of employees in the other entities, and intends to keep on focusing on manufacturing production solutions at the Bonn site, which remains the headquarter with focus on manufacturing, R&D and service. Also, Kautex Maschinenbau GmbH in Bonn will be the third overseas production base of Jwell.



For those employees, not being transferred to the new company a transfer company was installed to further qualify them for new external job opportunities. This opportunity was well received and 95% of employees took this chance to make progress in their professional careers. Kautex remains an independent operation within the Jwell Group and is intended to be its Premium Brand. With the transfer into a new company and the right-sizing of the staff base, first adjustments within the management have al-

ready been executed. Julia Keller, former CFO and CHRO of Kautex left the company and was replaced by Jun Lei as CFO. Maurice Mielke, until end of December 2023 Global Director R&D at Kautex was promoted to CTO and CHRO. Paulo Gomes, former CTO of the Kautex Group decided to leave the company, effective on February 1st.

Mr. He, president of Jwell, expressed this highest appreciation for all employees for the focused and dedicated work over last month and making this deal possible. He

stated that together we can realize a dream of many years, to operate an entity enterprise in Germany, and to lead Jwell to become one of the world leaders in the high-end extrusion machinery industry.

➔ **Kautex Maschinenbau GmbH**
www.kautex-group.com
 ➔ **Jwell Machinery Co. Ltd**
www.jwell.cn

Zumbach
 SWISS PRIME MEASURING SINCE 1957



2

Min. object diameter (mm)



100

Max. object diameter (mm)



up to 20

Scan rate (scans/s)

RAYEX® S

Static X-Ray

Measuring System

Benefits:

- ✓ All in one! Complete system for precision measurement of wallthickness, ovality, eccentricity and diameter.
- ✓ Fast measurement, immediate response to product changes.
- ✓ Operator friendly due to smart measurement algorithms.
- ✓ State of the art connectivity with integrated Profinet IO, Ethernet TCP/IP, Ethernet IP, or OPC UA communication protocols.
- ✓ Minimum maintenance requirement.



Zumbach Electronic AG

Hauptstrasse 93 | 2552 Orpund | Schweiz
 Telefon: +41 (0)32 356 04 00 | sales@zumbach.ch
www.zumbach.com

扩充在马来西亚提供的服务

■ 马格 (MAAG) 集团再次扩充了在亚洲的业务，宣布在马来西亚为马格 Ettliger 熔体过滤器提供新的服务。现在，除了切割转子再研磨外，马来西亚马格还可以提供真空热解炉清洗。

在塑料加工过程中，一些部件必须在漫长的工厂生命周期中进行维修、升级或更换。马格马来西亚为客户的高分子材料生产工厂提供全面的维修服务。该设施服务于亚洲大部分地区。

马格集团总裁 Ueli Thuerig 说：“我们对马来西亚的新增长感到兴奋。该项目标志着公司在我们预计长期需求强劲的战略市场扩大产能的计划的实施中的又一个重要里程碑。”

这些新扩充的服务是马格致力于亚洲市场的最新例证。



马格马来西亚团队

Team MAAG Malaysia

Expansion with Additional Services in Malaysia

■ MAAG Group has again expanded its operations in Asia, announcing new services in Malaysia for MAAG Ettliger melt filters. Now, in addition to, cutting rotor regrinding, MAAG Malaysia can also provide vacuum pyrolysis oven cleaning. In plastics processing some components have to be repaired, upgraded, or replac-

ed during the long plant lifecycle. MAAG Malaysia offers our customers comprehensive repair services for their polymer production plants. The facility serves most of Asia.

Ueli Thuerig, President of MAAG Group, said: “We are excited about our new Malaysian growth. This project marks another important milestone in the

implementation of the company’s plan to grow capacity in strategic markets where we expect strong long-term demand.” These additional services are the latest example of MAAG’s commitment to the Asian market.

► MAAG Group
www.maag.com

收购已完成

■ Davis-Standard 是挤出和加工技术设计和制造领域的全球领导者。我们非常荣幸地宣布已完成之前公告的对 Extrusion Technology Group (ETG) 的收购。

此次收购包括三个知名品牌：battenfeld-cincinnati、exelliq 和 Simplas。这些新增品牌正式加入 Davis-Standard 系列，标志着公司战略扩张的一个重要里程碑。此次收购进一步巩固了 Davis-Standard 作为行业领导者的地位，将其技术专长与 battenfeld-cincinnati、exelliq 和 Simplas 的创新技术和市场影响力相结合。凭借对卓越的共同承诺，统一的团队准备为全球客户提供无与伦比的解决方案和支持。

“我们很高兴正式欢迎 battenfeld-cincinnati、exelliq 和 Simplas 加入 Davis-Standard 大家庭。此次战略收购强化了我们为各行业客户提供尖端解决方案和全面支持的决心”，Davis-Standard 首席执行官 Giovanni Spitale 说。“我们将共同努力推动创新、提高运营效率并满足全球挤出和加工行业市场不断变化的需求。”

ETG 前首席执行官、现任 ETG 总裁兼 Davis Standard 执行领导团队成员 Gerold Schley 表示：“我们很高兴作为 Davis Standard 品牌家族的成员开启这一新篇章。ETG 和 Davis-Standard 之间的协同效应为合作、创新和增长提供了振奋人心的机会。” Schley 补充道：



“我们看到了众多的协同效应，这将使我们能够无缝整合，确保所有品牌的客户顺利过渡。”

将这些知名品牌整合到 Davis-Standard 产品组合中带来了丰富的知识、经验和先进技术。客户可以期待更多的产品品种、增强的服务能力以及更广泛的地域分布，以更好地满足他们的独特需求。

Davis-Standard 始终致力于为其客

户、合作伙伴和利益相关者提供价值。本公司对此次收购为合作、创新和增长创造的机会满怀热情。

Acquisition Completed

■ Davis-Standard announced that it has completed the previously announced acquisition of Extrusion Technology Group (ETG).

The acquisition includes three esteemed brands: battenfeld-cincinnati, Exelliq, and Simplas. These additions officially join the Davis-Standard family, marking a significant milestone in the company's strategic expansion. The acquisition further strengthens Davis-Standard's position as an industry leader, combining its expertise with the innovative technologies and market presence of battenfeld-cincinnati, Exelliq, and Simplas. With a shared commitment to excellence, the unified team is poised

to deliver unparalleled solutions and support to customers worldwide.

"We are thrilled to officially welcome battenfeld-cincinnati, Exelliq, and Simplas to the Davis-Standard family. This strategic acquisition reinforces our dedication to providing cutting-edge solutions and comprehensive support to our customers across various industries," said Giovanni Spitale, CEO of Davis-Standard. "Together, we are well-positioned to drive innovation, enhance operational efficiency, and meet the evolving needs of the global extrusion and converting market."

Former ETG CEO and now President of ETG and member of Davis Standard Executive Leadership Team Gerold Schley stated, "We are delighted to embark on this new chapter as part of the Davis-Standard family of brands. The synergies between ETG and Davis-Standard present exciting opportunities for collaboration, innovation, and growth." Schley added,

"We see numerous synergies that will allow us to integrate seamlessly, ensuring a smooth transition for customers of all brands."

Integrating these renowned brands into the Davis-Standard portfolio brings a wealth of knowledge, experience, and advanced technologies. Customers can expect an expanded product offering, increased service capabilities, and a broader geographical presence to serve their unique requirements better.

Davis-Standard remains committed to delivering value to its customers, partners, and stakeholders. The company is enthusiastic about the opportunities that this acquisition creates for collaboration, innovation, and growth.

➔ **Davis-Standard, LLC**
www.davis-standard.com



合作让废弃物获得第二次生命

■ 巴斯夫与在东南亚领先的再生颗粒料制造商Teamp拉斯集团合作，在巴斯夫IrgaCycle®添加剂的帮助下，将消费后废弃物转化为新的高品质办公设备部件及汽车内部饰件。

Teamp拉斯拥有广泛的本地家用产品、电器电子设备和报废车辆废弃物的收集商网络，生产再生颗粒料，主要用于电器用品。为了满足客户对高质量再生树脂日益增长的需求，Teamp拉斯决定使用IrgaCycle来增加聚烯烃塑料混合物的兼容性，并减轻再生过程的热应力和机械应力。

亚太地区塑料添加剂全球业务管理副总裁Hazel Sprafke说：“我们的首要任务是帮助Teamp拉斯控制再生物料质量的变化，并改善其最终产品的性能。”IrgaCycle是一种独特的添加剂组合，它是安全的，很容易根据需要进行计量，以尽量减少再生过程中杂质的影响。”

此外，使用IrgaCycle，Teamp拉斯可以改善使用再生物料生产的零部件的表面。制造椅子扶手、打印机外壳和汽车立体声装置的框架都可以获得更高的光泽度和更好的长期热稳定性。

使用IrgaCycle甚至可以采用100%再生颗粒料来生产这些成品。塑料在高价值应用中的使用推动了循环经济的增长，并有助于减少温室气体排放，对气候变化产生积极影响。

巴斯夫和Teamp拉斯之间的共同努力将继续下去，因为我们的目标是在包装行业使用IrgaCycle，“Teamp拉斯集团执行董事Pongsakorn Atichatsrisakul说。”我们与巴斯夫的伙伴关系不仅将帮助我们解决再生物料的质量问题，还将有助于实现泰国政府《塑料废物管理国家路线图》(2018-2030年)中提出的目标。”

作为巴斯夫系列产品组合VALERAS的一部分，IrgaCycle由一系列塑料添加剂配方组成，使再生塑料能够与纯新材料相结合，用于生产高价值的零部件。

Collaboration to Give Waste a Second Life

■ BASF and Teamp拉斯 Group, a leading manufacturer of recycled pellets in South-east Asia, have collaborated to transform post-consumer waste into new high-quality office equipment and car interior parts with the help of BASF's IrgaCycle®.

With a wide network of local waste collectors of household products, E&E equipment, and end-of-life vehicles, Teamp拉斯 produces recycled pellets for use mainly in electrical appliances. To address their

customers' growing demand for high-quality recycled resins, Teamp拉斯 decided to use IrgaCycle to compatibilize mixtures of polyolefin plastics and mitigate the thermal and mechanical stress of the recycling process.

“Our priority is to help Teamp拉斯 control the variation in the quality of recyclates and improve the performance of their final products,” said Hazel Sprafke, Vice President, Global Business Management, Plastic Additives, Asia Pacific. “As IrgaCycle is a unique combination of additives, it is safe and easy to dose as needed to minimize the impact of impurities in recyclates.”

In addition, with the use of IrgaCycle, Teamp拉斯 can improve the surfaces of parts produced using their recyclates. Chair armrests, printer exteriors, and car stereo frames can all be produced with higher gloss and greater long-term thermal stability.

IrgaCycle can even enable these finished products to be made with 100% recycled pellets. The use of plastics in high-value applications drives a growing circular economy and helps reduce greenhouse gas emissions for a positive impact on climate change.

“The joint efforts between BASF and Teamp拉斯 will continue as we aim to use IrgaCycle for applications in the packaging industry,” said Pongsakorn Atichatsrisakul, Executive Director of Teamp拉斯 Group. “Our partnership with BASF will not only help us tackle recycling quality but contribute to the goals laid out in the Thai government's National Roadmap on Plastic Waste Management (2018-2030).”

As part of BASF's VALERAS portfolio, IrgaCycle consists of a series of plastic additive formulations, which enable recycled plastics to be used for the production of high-value parts in combination with virgin materials.



➔ BASF plastic additives
www.plasticadditives.basf.com
www.performancechemicals.basf.com

宣布建立战略合作伙伴关系

■ 全球领先的高性能添加剂、工艺解决方案、药品和化学中间体开发商和制造商圣莱科特国际集团宣布与中国添加剂和其他特种化学品制造商辽宁鼎吉德石化有限公司（鼎吉德）建立长期供应合作伙伴关系。（圣莱科特国际集团宣布与辽宁鼎吉德石化有限公司（Liaoning Dingjide Petrochemical Co.（辽宁鼎际得石化有限公司（鼎际得）中国上海（CNY）是一家总部位于中国的添加剂和其他特种化学品制造商。通过此次合作，鼎际得将作为联合生产商在中国生产圣莱科特国际集团的某些产品。根据供应协议，圣莱科特国际集团将停止在中国金山工厂的生产运营，并将该工厂及相关法律实体挂牌出售。

SI 集团宣布与辽宁鼎吉德石油化工有限公司就某些产品在中国的销售建立战略合作伙伴关系根据协议条款，圣莱科特国际集团将继续向中国客户提供这些产品，并在中国境外分销和销售这些材料。圣莱科特国际集团将搬迁其目前位于金山的研发设施，并将继续运营其在中国的其余办事处和生产设施。圣莱科特国际集团高级副总裁、首席商务官 Joey Gullion 表示：“通过与鼎际得的合作，圣莱科特国际集团能够通过其全球销售和营销网络以及对创新的投资，专注于成为全球功能性添加剂的动力源，同时优化我们的业务范围并改变我们的成本结构。”

圣莱科特国际集团将继续朝着成为全球功能性添加剂动力源的愿景迈进，并将此次合作视为这一征程中的重要一步。圣莱科特国际集团总裁兼首席执行官 David Bradley 说：“圣莱科特国际集团在为全球各行业提供优质产品方面有着悠久的历史。作为我们业务战略的一部分，我们不断寻求新的方法来实现亚太地区和高增长。圣莱科特国际集团总裁兼首席执行官大卫·布拉德利（David Bradley）说：“除了我们的高质量标准和优质服务外，通过与鼎际得的协议建立的本地供应点也巩固了我们作为客户首选的主抗氧化剂供应商的地位。”

鼎际得公司将在其现代化的生产设施内生产，以坚持圣莱科特国际集团的高质量产品标准。“我们很高兴与圣莱科特国际集团达成长期战略协议。圣莱科特国际集团是添加剂领域的国际领先企业，通过与圣莱科特国际集团合作，鼎际得将利用其世界一流的质量和生产能力支持抗氧化剂在全球市场的增长，”辽宁鼎际得石化董事局主席张再明先生说。



圣莱科特国际集团的中国金山生产设施预计将于 2024 年 7 月 31 日停止生产运营。公司将立即挂牌出售并寻找买家。

Strategic Partnership Announced

■ SI Group, a leading global developer and manufacturer of performance additives, process solutions, pharmaceuticals and chemical intermediates, announced a long-term supply partnership with Liaoning Dingjide Petrochemical Co., Ltd. (Dingjide) Shanghai (CNY), a Chinese-based manufacturer of additives and other specialty chemicals. Through this partnership, Dingjide will manufacture certain SI Group products in China as a co-producer. As a result of the supply agreement, SI Group will cease manufacturing operations at its Jinshan, China manufacturing facility and list the property and associated legal entity for sale. Under terms of the agreement, SI Group will continue to offer these products to customers in China and will distribute and sell these materials outside of China. SI Group will seek to relocate its research and development facilities currently located in Jinshan and will continue to operate its remaining offices and manufacturing facility in China. “By partnering with Dingjide, SI Group is able focus on establishing global performance additives leadership through its global sales and marketing reach and investments in innovation, while optimizing our footprint and variablizing our cost structure,” said

Joey Gullion, SVP Chief Commercial Officer at SI Group.

SI Group continues to make progress toward the vision of being the global performance additives powerhouse and sees this partnership as a significant step in that journey. “SI Group has a long history of providing quality products to industries worldwide. As part of our business strategy, we continually seek new ways to realize quality growth in Asia Pacific and globally,” said David Bradley, President and CEO at SI Group. “In addition to our high-quality standards and excellent service, this local supply point through our agreement with Dingjide reinforces our position as a main antioxidant supplier of choice for our customers.”

Dingjide will uphold SI Group’s high quality product standards with production at its modern manufacturing facility. “We’re very pleased to enter into a long-term strategic agreement with SI Group. By partnering with SI Group, an international leader in additives, Dingjide will leverage its world-class quality and production capabilities to support antioxidant growth in the global marketplace,” said Zaiming Zhang, Chairman of Board of Directors, Liaoning Dingjide Petrochemical.

SI Group’s Jinshan, China manufacturing facility is expected to cease manufacturing operations on July 31, 2024. The company will list the site for sale and seek a buyer immediately.

► SI Group
www.siigroup.com

市场领导地位得到加强

■ 欧洲领先的二手工业机器交易平台 GINDUMAC 在技术和流程不断增强的推动下，在2023年再次创造了创纪录的业绩，实现了盈利增长。

在900多台金属、钣金和塑料加工类别的直接可用的机器支持下，德国（DACH）和欧洲/中东及非洲（EMEA）的订单量增加了一倍。过去几年，GINDUMAC 将平台业务和交易管理专业知识结合起来，已成为欧洲的市场领导者。

GINDUMAC 联席首席执行官 Benedikt Ruf 表示：“我们在2023年又实现了一个出色的年度，强调流程效率和客户邻近性。我们成功地确保了大量的市场份额，最大限度地提高了客户满意度，并提高了我们产品的质量。”

尽管德国二手机械市场的市场条件充满挑战，全球市场的宏观经济持续不确定性，但 GINDUMAC 计划2024年实现两位数的增长。

GINDUMAC 联席首席执行官丹尼尔 Kaiser 说：“我们2024年的重点是扩大我们在欧洲的网络。在亚洲，我们将利用创新的销售战略，战略性地扩大我们的存在。我们今年的主要目标仍然是为客户精简和优化使用平台技术的二手机械业务。”

Market Leadership Strengthened

■ GINDUMAC, Europe's leading transactional platform for used industrial machines, again generated record-breaking results with profitable growth in 2023, powered by ongoing enhancements of technologies and processes.

Order intake doubled in DACH and EMEA supported by more than 900 directly available machines in the categories metal, sheet metal and plastics processing. Over the past years, GINDUMAC has emerged as market leader in Europe, combining platform business and transaction management expertise.

Benedikt Ruf, Co-CEO of GINDUMAC, remarks, "We achieved another outstanding year in 2023, emphasizing process efficiency and customer proximity. We successfully secured substantial market share, maximized customer satisfaction, and enhanced the quality of our offerings."

Despite challenging market conditions in the used machinery market in Germany



GINDUMAC 集团联席首席执行官: Benedikt Ruf 和 Daniel Kaiser (从左至右)

The Co-CEOs of the GINDUMAC Group: Benedikt Ruf and Daniel Kaiser (from left to right)

and continued macroeconomic uncertainty on the global markets, GINDUMAC is planning double-digit growth for 2024. "Our focus for 2024 is expanding our network across Europe," states Daniel Kaiser, Co-CEO of GINDUMAC. "In Asia, we will leverage innovative sales strategies to strategically expand our presence.

Our primary objective this year remains to streamline and optimize the used machinery business with platform technology for our customers."

➔ GINDUMAC GmbH
www.gindumac.com

工业涂料和无聚四氟乙烯添加剂的新组合

■ 在上海举行的 ChinaCoat 2023 中国国际涂料展会上，科莱恩（Clariant）展示了其致力于更可持续和有效的配方和涂料应用的最新解决方案，以帮助维护公众健康和环境。

中国涂料行业继续强劲增长，在疫情后迎来了强劲的复苏。这种增长是由出口及建筑等行业对涂层应用的需求所推动的，这类行业要求提供更高的效率及更好的性能。为了满足这些需求，科莱恩提供了专门的解决方案，包括在不断变化的系统中提高耐腐蚀性和降低配方粘度。

ClariCoat 数字平台：在中国的一站式添加剂商店

为了更容易找到正确的添加剂，科

莱恩推出了新的中国版本的 ClariCoat 数字平台。为涂料配方面临挑战的涂料和涂料专家提供了新的网络应用程序，为液体涂料的稳定性、可操作性和可持续性等整体性能标准提供了按需定制的解决方案。

随着行业继续向水性涂料系统转变的趋势，数字工具对需要添加剂建议的配方师尤其有价值。

满足对不含聚四氟乙烯解决方案日益增长的需求

除了性能和可持续性外，遵守监管要求也越来越受到整个涂料行业的关注。例如，在油墨配方和涂料应用中使用聚四氟乙烯（PTFE）已在欧盟、美国和

日本受到监管，从而产生了对不含聚四氟乙烯的替代品的需求。科莱恩不断增长的无聚四氟乙烯解决方案组合是2023中国国际涂料展的亮点。

科莱恩涂料和粘合剂、BU吸附剂和添加剂营销主管Ray Gonzales说道：“我们很高兴分享涂料和油墨的持续发展，部分原因是我们的新型添加剂解决方案，这让我们在建筑、家具和其他应用中可以选择不含聚四氟乙烯的替代品。我们为我们的不含聚四氟乙烯替代品感到自豪，如Ceridust®8170 M，表明我们的企业致力于尽量减少对环境的影响。”

Ceridust 8170 M是一种创新的无聚四氟乙烯粉末涂料纹理剂。它在粉末涂料挤压过程中具有减少能源消耗的额外好处，并符合欧盟的REACH《化学品注册、评估、许可和限制》法规，此外它也不含PFAS（聚合物氟化物）。

除了Ceridust 8170 M，Ceridust 8330是ChinaCoat的特色，它是一种不含聚四氟乙烯的替代品，具有优异的耐磨性。这种独特的生物基添加剂由可再生资源制成，是各种涂料和油墨的突破，与传统的蜡基产品相比，表现出卓越的耐摩擦性能。Ceridust 8330可用于水性和溶剂型涂料系统，与含有聚四氟乙烯的材料相比，使用Ceridust 8330可实现类似或更优越的性能，从而更高效地使用油墨。

以可持续发展为驱动力的高性能、脱碳和本地化配方

Sustainability-driven formulations on performance, decarbonization and localization

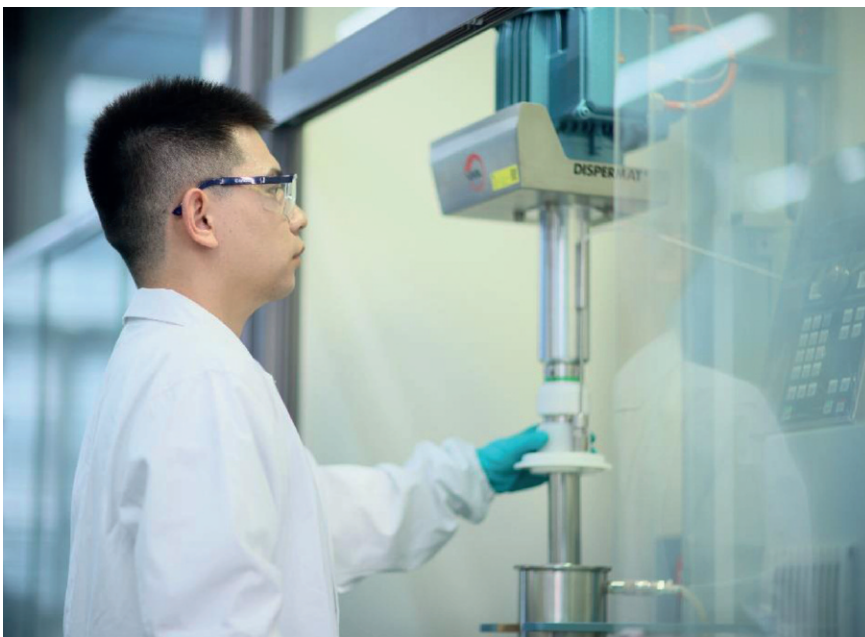

New Portfolio of Industrial Coatings and PTFE-free Additives

■ At ChinaCoat 2023 in Shanghai Clariant showcased its latest solutions dedicated to more sustainable and effective formulations and coating applications that help safeguard public health and the environment.

The coatings industry continues to grow strongly in China, experiencing a strong recovery in the aftermath of the pandemic. This growth is being driven by demand in industries such as export and construction for coating applications that offer both higher efficiency and better performance. To meet these needs, Clariant offers dedicated solutions with features including improved corrosion resistance and reduced formulation viscosity consistently achieved across changing systems.

ClariCoat in China – a one stop additive shop

To make it easier to find the right additives Clariant has launched a new Chinese version of its ClariCoat digital platform. The novel web application for paints and coatings specialists who face challenges with their paint formulations provides customized solutions for a holistic

range of performance criteria such as liquid paint stability, workability and sustainability.

The digital tool is particularly valuable for formulators who want advice on additives as the trend to shift towards water-based paint systems continues in the industry.

Meeting growing demand on PTFE-free solutions

In addition to performance and sustainability, compliance with regulatory requirements is growing concern for the coatings industry as a whole. For example, the use of polytetrafluoroethylene (PTFE) in ink formulations and coating applications has been regulated in the EU, the US and Japan, creating the need for PTFE-free alternatives. Clariant's growing portfolio of PTFE-free solutions were a highlight at ChinaCoat 2023.

“We are excited to share the ongoing evolution of coatings and inks, driven in part by our novel additive solutions, which have given us the choice of PTFE-free alternatives in construction, furniture and other applications. We are proud of our PTFE-free alternatives, like Ceridust® 8170 M, demonstrating our corporate dedication to minimizing environmental impact,” says Ray Gonzales, Clariant's Head of marketing Coatings & Adhesives, BU Adsorbents and Additives.

The Ceridust 8170 M is an innovative PTFE-free texturing agent for powder coatings. It has the added benefit of reduced energy consumption during the powder coating extrusion process and complies with the EU's REACH legislation in addition to also being PFAS-free.

In addition to Ceridust 8170 M, Ceridust 8330 was a feature at ChinaCoat as a PTFE-free alternative with excellent abrasion resistance. This unique bio-based additive, made from a renewable resource, is a breakthrough for various coatings and inks, exhibiting superior rub resistance properties compared to conventional wax-based products. It can be incorporated in both water and solvent-based coating systems and formulations using Ceridust 8330 can achieve similar or superior performance compared to PTFE-containing materials, leading to more efficient ink usage.

出新型500系列橡胶/硅胶挤压十字头

■ Guill Tool推出了具有MAGS胶空间调节系统的新型500系列十字头。500系列专为弹性体化合物的流动特性和独特的加工挑战而设计。Guill推出的这种新型十字头设计的关键特性之一是机械辅助胶空间 (MAGS) 调节系统。新的胶空间调节方法使操作员可以使用普通套筒扳手从单点进行轻松调节。调节胶空间时无需多个螺母和螺栓，这可以缩短调节时间。核心管上的视觉指示灯让操作员能够查看胶空间移动了多远，使调节更加准确且可重复。

Guill推出的新型500系列无需硬件并采用专利凸轮锁设计，无需浪费时间拆卸和重新固定紧固件，便于拆卸和重新组装。只需将凸轮螺母转半圈即可松开并自动从十字头头部取出导流板，这进一步节省了时间。此外，导流板上没有底切，在取出导流板时无需挂起任何材料，从而可以更快地、更轻松地进行清洁和转换。

新型500系列还采用了最新的中央平台同心度调节系统，可显著降低工具压力，可以在不松动端面螺栓的情况下更轻松、更精确地进行同心度调节。用于调节螺栓的易取插件还允许轻松地更换锁定或损坏的调节螺栓，从而进一步减少维修费用并减少宕机时间。

这种新型橡胶/硅胶十字头的另一个创新特点是铸铝液体冷却套管，让用户可以在发生线路阻塞时切换冷却套管，与传统集成冷却系统相比，进一步减少了宕机时间。

Guill 500系列十字头，具有机械辅助胶空间 (MAGS) 调节系统.....专为弹性体化合物的流动特性而设计

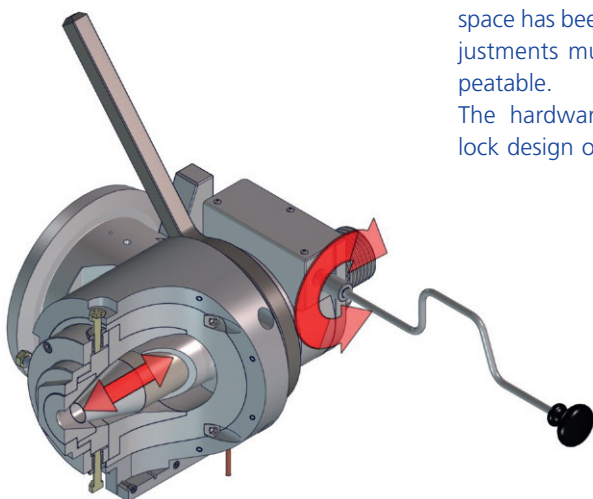

带有MAGS胶空间调节功能的新型500系列十字头是大多数现有NRM生产线的直接替代品，但这种十字头设计也可以适应任何挤压机设计或生产线布局。

添加了新设计的流入口通道后，可减少材料加工时产生的剪切力和热量，这有助于降低十字头的压力，使材料以更平衡和均匀流动的方式穿过十字头。

Guill提供的所有十字头都配有用于装配和拆卸的工具套件以及详细的操作员说明手册。Guill工程团队可随时协助用户实施和操作新型500系列十字头。

有关具有MAGS胶空间调节系统的新型Guill 500系列十字头的视频，请访问：

<https://youtu.be/jeNovmMtcBs>

New 500 Series Rubber/Silicone Extrusion Crosshead

■ Guill Tool introduces the NEW 500 Series crosshead with MAGS gum space adjustment. The 500 Series is designed specifically for the flow characteristics and unique processing challenges of elastomeric compounds. One of the key features engineered by Guill on this new crosshead design is the mechanically assisted gum space (MAGS) adjustment system. This new method of gum space adjustment allows the operator to make an effortless adjustment from a single point using a common socket wrench. No more need to struggle with multiple nuts and bolts in order to adjust gum space, which leads to faster adjustments. The visual indicator on the core tube allows the operator to see how far the gum space has been moved, making those adjustments much more accurate and repeatable.

The hardware-free and patented cam lock design of the NEW 500 Series from

Guill Series 500 crosshead with Mechanically Assisted Gum Space (MAGS) adjustment...specially designed for the flow characteristics of elastomeric compounds

Guill means no time is wasted unbolting and re-securing fasteners for disassembly and re-assembly. Only half of a rotation of the cam nut is required to loosen and automatically extract the deflector from the head body, which is another time saver. Also, with no undercuts on the deflector, there are no material hang-ups when extracting the deflector, allowing for faster and easier cleaning and changeover.

The NEW 500 Series also features the latest Center-Stage concentricity adjustment system that significantly reduces pressure on the tooling, allowing easier and more precise concentricity adjustments without loosening the face bolts. Easy-Out inserts for the adjusting bolts also allow simple replacement of locked or damaged adjusting bolts, which further saves on repair and downtime.

Another innovative feature of this new rubber/silicone crosshead is a cast aluminum liquid-fed cooling sleeve that allows the user to switch out the cooling jacket in the event of a line obstruction, again reducing downtime compared to traditional integrated cooling systems.

The NEW 500 Series crosshead with MAGS gum space adjustment is a drop-in replacement on most existing NRM lines, however this crosshead design can also be adapted to fit any extruder design or line layout.

The addition of a newly designed flow inlet channel reduces the shear and heat that is generated as the materials are being processed. This leads to lower head pressures allowing the material to move through the head in a much more balanced and even flow.

All crossheads supplied by Guill are furnished with a tool kit for assembly and disassembly as well as a detailed operator's instruction manual. The engineering team at Guill will gladly assist users in the implementation and operation of the NEW 500 series crosshead.

For a video of the NEW Guill 500 Series crosshead with MAGS gum space adjustment, please go to:

<https://youtu.be/jeNovmMtcBs>

► **Guill Tool & Engineering**
www.guill.com

宣布全球公司更名

■ Mylar Specialty Films是差异化聚酯薄膜生产的领导者，它公布了其全球品牌重塑计划，重点是将名称从DuPont Teijin Films（杜邦帝人薄膜）更改为Mylar Specialty Films。这一变化适用于位于美国、欧洲和亚洲的所有全球业务和办事处。新公司名称的选择反映了Mylar®品牌的传统，该品牌在20世纪50年代作为世界上第一个双向拉伸聚酯薄膜推出。

Mylar Specialty films首席执行官 Steve Gendreau说道：“在我们70年生产Mylar®聚酯薄膜的基础上，这次更名是对我们历史的致敬，也表明我们继续致力于创新和在市场上的领导地位。”Mylar特种薄膜不仅准备满足我们行业不断变化的需求，而且还预测到这些需求，并以我们对卓越的全球客户的承诺制定行业标准。”

公司所有权保持不变，为Celanese和Teijin的合资企业，公司将继续销售Melinex®PET、Hongji®PET和Kaladex®PEN系列产品，以及Mylar®PET品牌薄膜。

与FSPG高科技有限公司在中国的合资业务也将在不久的将来重新命名，但将继续以杜邦鸿基薄膜公司的名义运营，直到另行通知。

Global Company Name Rebrand Announced

■ Mylar Specialty Films, a leader in the production of differentiated polyester films, unveiled its global rebranding initiative highlighted by a change in name from DuPont Teijin Films to Mylar Specialty Films. This change applies to all global operations and offices located in the US, Europe and Asia. The choice of the new company name reflects the heritage of the Mylar® brand which was introduced as the world's first biaxially orientated PET film in the 1950's.

“Proudly building on our 70-years of producing Mylar® polyester films, this rebranding is a salute to our history as well as signals our continued commitment to innovation and leadership in the market,” said Steve Gendreau, CEO of Mylar Specialty Films. “Mylar Specialty Films is poised to not only meet the evolving needs of our industry, but to also anticipate them and set industry standards with our com-

mitment to excellence and to our customers worldwide.”

The company ownership remains unchanged being a joint venture between Celanese and Teijin, and the company will continue to market the Melinex® PET, Hongji® PET, and Kaladex® PEN range of products in addition to Mylar® PET branded films.

The JV operations with FSPG Hi-Tech Co., Ltd in China will also be re-branded in the near future but will continue to operate as DuPont Hongji Films until further notice.

► Mylar Specialty Films
www.mylar.com

SIKORA
Technology To Perfection

Chinaplas® 2024

欢迎莅临
2024 CHINAPLAS
我司展位 2.1F62

CENTERWAVE 6000 360° 测量大规格管道

- 测量外径在 32 - 3,200 mm 的管材
- 最小壁厚 1.6 mm
- “一键式操作”—— 无需校准，无需预设产品参数
- 对管道进行 360° 测量
- 冷值的动态收缩与熔垂预测

Video link

www.sikora.net

庆祝在中国的第二个工厂开业

■ Orion公司庆祝其第一个绿地项目的完成，这是一个位于中国东部的炭黑工厂，将满足亚洲快速增长的需求。

该工厂位于安徽省淮北市，将生产各种用途的炭黑，包括涂料、印刷油墨、橡胶、高分子材料、纤维和橡胶。该工厂的两条生产线的总产能为每年7万吨。

“淮北基地对Orion来说是一个巨大的里程碑。最先进的工厂使我们能够更好地为中国客户提供中国制造的产品，”Orion首席执行官Corning Painter（康宁·佩因特）在11月17日的开幕式上说：

“现在我们可以重新分配美国和欧洲的生产线，这样我们就可以增加对这些市场客户的供应。”

Orion在中国的另一家工厂位于东部省份山东的青岛。该工厂建于1994年，生产轮胎、机械橡胶制品和特殊应用等级的炭黑。

Painter赞扬淮北项目组的每个人都克服了Covid-19病毒带来的极端挑战。

首席执行官说：“尽管在疫情最严重的时期持续运营中断，但我们的员工、承包商和领导团队保持了项目的正确轨道。一如既往，我们把人民的安全、健康和福利放在首位，提供营养膳食、温暖的床、检测和医疗服务。但仍然是我们团队的英雄奉献精神，在极其艰难的情况下交付了这个项目。”

Opening of the Second Plant in China Celebrated

■ Orion has celebrated the completion of its first greenfield project – a carbon black plant in eastern China that will supply fast-growing demand in Asia.

The facility in the city of Huaibei in Anhui province will produce carbon black for a variety of applications, including coatings, printing inks, rubber, polymers, fiber and rubber. The site's two production lines have a total capacity of 70 kilotons per year.

“The Huaibei facility is a huge milestone for Orion. The state-of-the-art plant enables us to better support our Chinese customers with products that are made in China,” Orion CEO Corning Painter said at the Nov. 17 opening ceremony. “Now we can reallocate production lines in the U.S. and Europe so that we can increase supply to customers in those markets.”



Orion 庆祝其首个新建项目--位于中国东部的炭黑工厂竣工

Orion has celebrated the completion of its first greenfield project – a carbon black plant in eastern China

Orion's other plant in China is in Qingdao in the eastern province of Shandong. The facility, built in 1994, produces carbon black grades for tires, mechanical rubber goods and specialty applications.

Painter commended everyone on the Huaibei project team for overcoming the extreme challenges posed by the Covid-19 virus.

“Despite the constant disruption during the worst periods of the pandemic, our employees, contractors and leadership

team kept the project on track,” the CEO said. “As always, we put the safety, health and the welfare of our people first, providing nutritious meals, warm beds, testing and medical care. But still, it was the heroic dedication of our team that delivered this project under extremely trying circumstances.”

► Orion S.A.
orioncarbons.com

世界市场的领导者

■ 每年，圣加伦大学与德国全球市场领导者学会合作，列出451名德国全球市场领导者。该基础数据由一个数据库提供，目前约有1300个关于潜在世界市场领导者的条目。这些公司是根据严格的标准和规则筛选和选择的。因此，摩丹（Motan）集团再次被公认为世界市场的领导者。

除其它外，全球市场领导者必须在相关细分市场的营业额方面位居全球第一或第二位。摩丹集团的年营业额约为1.47亿欧元，处于非常有利的地位。此外，潜在的世界市场领导者的全球年营业额中至少有50%必须在海外和三个大洲产生。摩丹在六大洲的出口配额为大于50%，再次超过了这一标准。

另一个标准是业主总部，至少在一

定程度上位于德国。摩丹集团在Constance（康斯坦茨）的位置也完全符合这一标准。

451家全球市场领导者的完整名单刊登在本期特刊第一期。2023年11月6日德国商业周刊《WirtschaftsWoche》的第1期，标题是“450个隐密的世界市场领导者”。

World Market Leaders

■ Every year, the University of St. Gallen, in cooperation with the Academy of German Global Market Leaders, lists 451 German global market leaders. The basis is provided by a database with currently around 1300 entries of potential world market leaders. These companies are filtered and selected according to strict cri-

teria and rules. Thus, the motan Group was once again recognized as a world market leader.

World market leaders must, among other things, be number one or two worldwide in terms of turnover in a relevant market segment. With an annual turnover of around 147 million euros, the motan Group is in an excellent position. In addition, at least 50% of the global annual

turnover of potential world market leaders must be generated abroad and on three continents. With an export quota of >50% on six continents, motan has again more than fulfilled this criterion.

Another criterion is the headquarters of the owners. This must be, at least in part, in Germany. The motan Group also fully meets this criterion with its location in Constance.

The complete list of the 451 world market leaders is published in the current special issue no. 1 of "WirtschaftsWoche" from November 6, 2023 with the title: "The 450 secret world market leaders".

► **motan holding gmbh**
www.motan-group.com

收购中国伙伴的少数股权

■ 可持续解决方案供应商Perstorp (柏斯托) 已完成收购其在合营企业山东柏斯托化工有限公司(前称山东富丰柏斯托化工有限公司)少数股权的交易, 该合营企业拥有及经营中国淄博的设施。柏斯托现为多元醇制造业务的唯一拥有人, 该设施位于山东淄博, 在北京以南约400公里处。

该交易突显了柏斯托对中国和亚洲市场的持续坚定承诺, 完全符合公司的战略方向和可持续发展目标。

山东富丰柏斯托化工有限公司成立于2007年, 由柏斯托与其中方合作伙伴山东富丰宏金投资有限公司共同出资组建。获得完全所有权将确保柏斯托能够继续开发该设施, 并能够进行实质性的设施升级, 以保障淄博设施的竞争力。

柏斯托集成供应链执行副总裁 Magnus Lannér 说道: "实现我们的长期战略方向和2030年的可持续发展目标意味着我们需要发展我们的业务和运营我们设施的方式。我们的目标是在淄博继续发展安全、可持续和卓越的运营"。

根据本公司雄心勃勃的2030年可持续发展目标, 柏斯托制定了可操作的路线图, 概述了减少温室气体排放、减少浪费、节约淡水及实现整个价值链的可持续转型的实践活动。对于淄博设施的运营, 范围1路线图包含了一些旨在减少排放, 同时也最大限度地减少废物产生和水消耗的项目。

作为交易的一部分, 淄博基地的业务已更名为山东珀斯托化工有限公司。公司原名山东富丰柏斯托化工有限公司。

Minority Partner in China Acquired

■ Sustainable solutions provider Perstorp has closed a deal to buy out its minority partner in the joint venture Shandong Perstorp Chemical Co., Ltd. (formerly Shandong Fufeng Perstorp Chemical Co., Ltd.), which has owned and operated Site Zibo in China. Perstorp is now the sole owner of the polyol manufacturing operation,

located in Zibo, Shandong province, about 400 km south of Beijing.

The deal underscores Perstorp's continued strong commitment to China and the Asian market and is fully in line with the company's strategic direction and sustainability agenda.

Shandong Fufeng Perstorp Chemical Co at Site Zibo was established as a joint venture between Perstorp and their Chinese partner Shandong Fufeng Hongjin Investment Co., Ltd. in 2007. Gaining full ownership will ensure that Perstorp can continue developing the site, and can aim to make substantial site upgrades to safeguard the competitiveness of Site Zibo.

"Reaching our long-term strategic direction and our sustainability targets for 2030 mean that we need to develop both our business and the way we operate our site. Our ambition is to continue developing safety, sustainability and operational excellence at Site Zibo," says Magnus Lannér, EVP Integrated Supply Chain.

Based on the company's ambitious sustainability targets for 2030, Perstorp has developed actionable roadmaps outlining hands-on activities to lower greenhouse gas emissions, reduce waste, save fresh water and enable sustainable transformation throughout the value chain. For the operations at Site Zibo, the Scope 1 roadmap contains a number of projects designed to reduce emission while also minimizing waster production and water consumption.

As part of the deal, the operations at Site Zibo has changed its name to Shandong Perstorp Chemical Co., Ltd. Its former name is Shandong Fufeng Perstorp Chemical Co., Ltd.

► **Perstorp**
www.perstorp.com



柏斯托收购了中国设施的少数股权
(照片: 柏斯托)

Perstorp buys out minority partner at China site
(Photo: Perstorp)

挤压技术新发展

Extrusion Tooling: Extrusion Takes Some New Turns



Guill Tool 公司位于美国罗德岛州西沃里克市，多年来一直是医用管材和其他产品挤压模具领域的全球领导者，并在多层共挤模具领域取得了诸多成就。

A longtime global leader in extrusion tooling for medical tubing and other products, Guill Tool has achieved a series of successes in the areas of multi-layer dies and, most recently, a reciprocal tubing die for wound draining that reconfigures the internal chambers of the tubing to accommodate drainage.

最近，该公司又推出了一款往复式伤口引流管模具，此款模具可以重新配置管材的内腔，以适应引流的需要。引流管可用于预防性插入，以防止或清除伤口积液，也可用于治疗性插入，以排出伤口内现有积液。排出积液是为了治疗或预防感染，促进伤口愈合，并提升病人舒适度。引流管还可用于诊断术后并发症，如吻合口瘘或出血。Guill 的模具设计具有独特的功能，无需以焊接等方式连接不同型材的截面。

“我们的自动挤压工艺可在生产中显著改变挤压型材，无需连接内部型材的不同截面。” – Tom Baldock, Guill Tool 销售经理。

Guill 设计的这款新型往复式管材模具具有多种独特功能。传统的头端和模具组件由线性往复式组件代替，该组件在给定

长度内改变管材的外形。此过程在挤出全程不间断地重复进行。切割能力外加挤出速度将成品切割成一定的长度。

可降低成本和减少价值流活动，同时提升质量。一次挤压即可产出成品，无需多次挤压、更换模具，以及通过声波焊接等连接方法手工组装不同形状的管材。Guill 的新型往复式挤压头完全消除了装配操作。它还消除了在制品库存。因此，无需储存装配、订单履单和成品补给所需的各种形状的管材和接头。

此外，往复式挤压头消除了连接件，允许准时生产和按订单生产产品。最后，它还缩短了从接收订单到发货的总运行时间。

在 Guill Tool 多年来优先关注的多层共挤领域，该公司还

推出了最新款 Series 800，这是一款 2 至 6 层挤出模具，旨在生产面向医疗和外科应用的 1/8" 至 6" 外径管材，具有出色的质量和材料效率。经过重新设计的 Series 800 可实现含氟聚合物和其他材料的无缝平滑挤出和分层，适用于所有多层、多腔医用管材。Guill 的设计进一步允许聚合物和粘合剂的薄层（0.02 毫米以下）组合。

Guill 提供各种十字头和内联管路模具，具有固定或可调节中心，适用于单挤压或共挤压应用。该模具旨在用于加工所有化合物，具有公司享有专利的精密 Feather Touch 同心度调节器，即 Seal Right 系统，该系统与 Feather Touch 系统相结合，消除了聚合物泄漏。Guill 还提供独特的螺旋流量分配系统。

所有 Guill 模具的生产都利用计算流体力学 (CFD) 程序进行了严格的流道计算机模拟，从而优化均匀流动，而且没有接合线。

最后，Guill Tool 全新推出的 Series 900 内联管路模具实行标准定价，并提供更好的挤出性能和定制能力。

这个新系列适用于直径从 0.005 英寸（0.127 毫米）到 8.0 英寸（635 毫米）的软管或管材挤出，以及各类聚合物或橡胶 OEM、食品服务、汽车、工业、电信和医疗应用。

Series 900 技术具有以下主要优点：

- 实现同心度或“产品圆度”，与其他类型的挤出模具相比，可显著降低材料用量
- 无十字线内联设计挤压头不会产生十字线，从而允许更多空气进入，无需可能限制产品产量的冷却支架
- 可同时运行 1-5 层
- 专为多种应用而设计，包括特殊的含氟聚合物应用

Guill Tool Series 900 的一个主要技术亮点是正在申请专利的 FeatherTouch™ 模座调节装置，以及无需松开固定螺钉即可进行调节的筒式滚珠组件。Series 900 的其他独特优势

还包括 Guill 的 Seal Right Systems，该系统带来良好的密封性，可消除导流板之间的泄漏，而且易于自动对准，可减少装配过程中的操作错误，并适应各种特定的挤出机布局配置。

“这个系列提供面向挤压头的标准平台设计，以及针对具体应用的独特功能，且不会增加模具成本。因而，企业能以标准价格获得可定制的精密切具，这是一项卓越优势。这无疑可帮助我们的客户提升利润。”Guill 销售经理 Tom Baldock 表示。

Guill Tool 还使用最先进的计算机数控机床和 EDM 设备制造喷嘴、模具和断流板。此外，该公司还提供工程服务，使用最新的 CAD 系统来定制设计挤压模具产品，如十字头、喷嘴、夹具、法兰、成型辊、无十字网内联模具、模具、摆门、断流板、专用设备和定径模具。

Guill Tool 于 1995 年获得 ISO 认证。作为首家达到国际标准的大型挤出模具公司，Guill Tool 长期以来一直被公认为是定制挤出模具的领先设计商和制造商之一，其产品应用领域包括电线、电缆、光纤、医用管材、木质复合材料、汽车管、塑料复合、定制应用、橡胶、型材、工业管材、软管/管材、吹塑以及食品和包装等。

Guill Tool 还鼓励并为挤出行业提供教育和培训，包括塑料和铝制模型挤压头、图文并茂的分步组装和拆卸操作手册、培训视频以及挤出模具的维护和清洁课程。

Guill Tool 成立于 1962 年，由 A. Roger Guillemette 在罗德岛创立，最初是为新英格兰地区的电线、电缆或电线电缆、塑料和橡胶行业提供喷嘴、模具、十字头和替换部件的加工厂。后来，Guill Tool 逐步成为整个美国和加拿大的供应商，并迈入全球市场。

医疗领域的技术不断发展，通常需要各种材料和厚度的医疗级管材。Guill 专注于与客户合作设计和制造定制挤压工具，以生产业内最高质量的医用管材。该公司的 Micro Medical 模具可挤出比头发丝更细的管材，每转 0.008 英寸或更细，从而尽可能实现微创手术。其他型号可用于生产喂食管用管，包括鼻胃管和空肠管。

各种伤口引流管和手术管设计的内部配置无需再分别挤出和截面连接。Guill 的往复式挤压头设计可连续生产管材内的各种型材

Internal configurations of different designs used on wound drain and surgical tubing no longer require separate sections to be extruded, then joined. The Guill reciprocating head design produces various profiles within the tubing in a constant production run

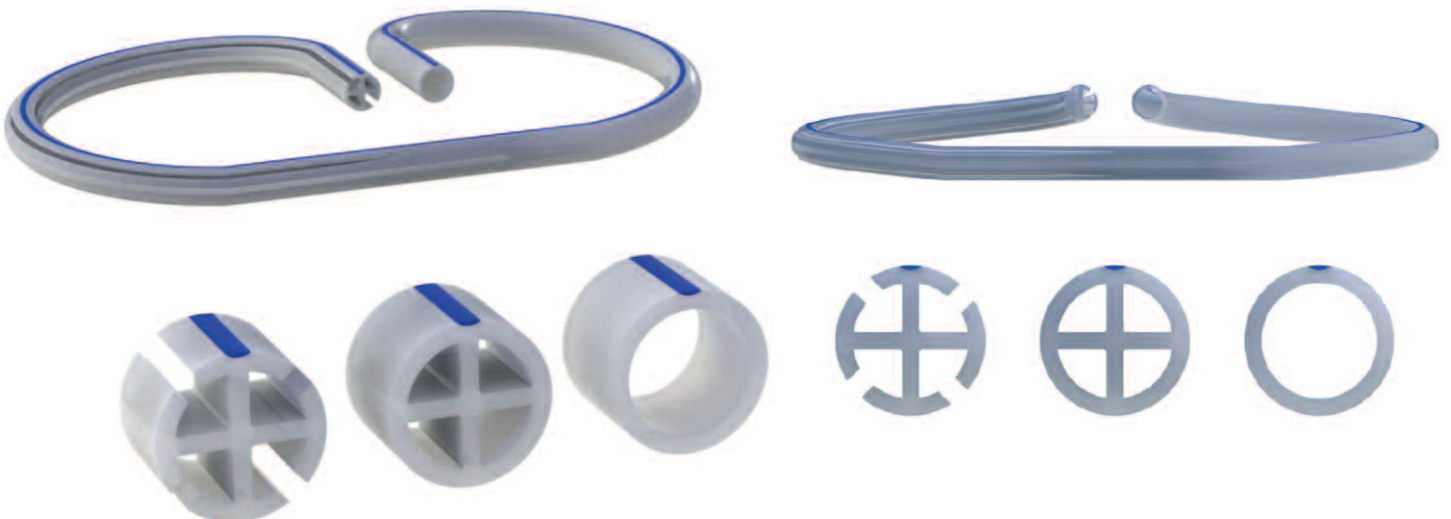

Drain tubes can be inserted prophylactically to prevent or remove the accumulation of fluid in a wound. Alternatively, such tubing can also be therapeutically inserted to evacuate an existing collection of fluid in a wound. Fluid is removed in order to treat or prevent infection and promote wound healing and patient comfort. Drain tubes can also be used to diagnose post-operative complications such as an anastomotic leak or hemorrhage. The Guill design has unique features that eliminate the need to weld or otherwise join sections with different profiles together.

“Our automated extrusion process drastically changes the extruded profile in production, with no need to join separate sections of internal profiles,” comments Tom Baldock, Sales Manager, Guill Tool

Guill has engineered this new reciprocal tubing die with various features, unique to the product. The traditional tip and die assembly is replaced with a linear reciprocating assembly that changes the tube's profile within a given length. This process is repeated throughout a single extrusion run without interruption. Cutting capability, in association with the extrusion speed, cuts the finished product to length.

While cost and value stream activities are reduced, quality is actually improved. Only one extrusion run is needed to produce a finished product, as opposed to multiple extrusion runs with tooling changes along with a manual assembly operation to connect different tubing shapes via sonic welds or other methods of joining. Guill's new reciprocating head eliminates this entire assembly operation. It also eliminates in-process inventory. Thus, there is no need for storage of various tubing shapes and connectors needed for assembly, fulfillment of orders and replenishment of finished goods.

Furthermore, the reciprocating head eliminates a connecting piece, allows JIT production and products made-to-order. Lastly, it reduces total run time from receiving the order to shipping product.

In the multi-layer extrusion arena, a primary focus of Guill Tool over the years, the company has also introduced the latest generation of its Series 800, the 2-to-6 layer extrusion tooling designed to produce the highest quality, highest material-efficient 1/8" to 6" OD tubing for medical and surgical applications. The redesigned Series 800 produces flawlessly smooth extrusion and layer definition of Fluoropolymer and other materials for all multi-layer, multi-lumen medical tubing. The Guill design further allows thin layer combinations of polymers and adhesives to 0.02mm or less.

Guill offers its extensive line of crossheads and inline tubing dies in fixed and adjustable center, for single or co-extrusion applications. The tooling is designed to process all compounds and features the company's patented, precision Feather Touch Concentricity adjustment, the Seal Right System, which combines with the Feather Touch system to eliminate polymer leaking. Guill also offers its unique spiral flow distribution system.

All Guill tooling is produced with rigorous computer simulation of the flow channels using Computational Fluid Dynamics (CFD) programs, resulting in optimum uniform flow with no weld lines. Finally, the new Series 900 of inline tubing dies from Guill Tool offers improved extrusion performance and capabilities to customize at standard, off-the-shelf prices.

The new series is applicable to extrusion of hose or pipe ranging from 0.005" (0.127mm) to 8.0" (635mm) in diameter for all types of OEM, food service, automotive, industrial, telecom and medical applications in polymer or rubber.

Guill Series 800

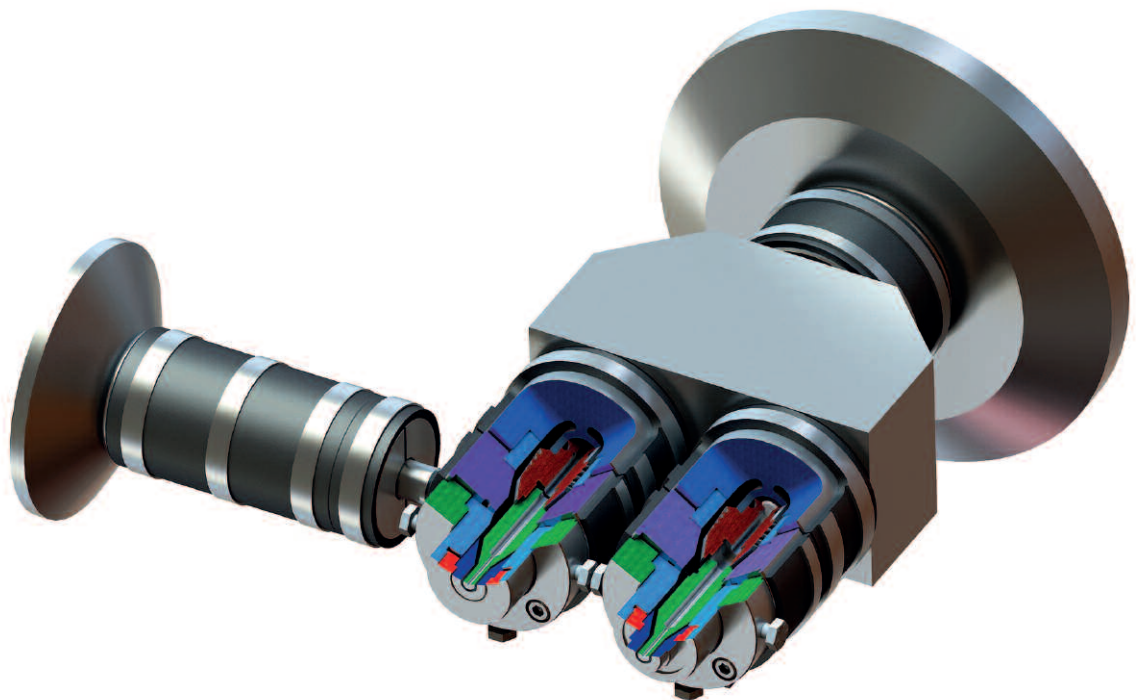

Guill Series 900

The Series 900 technology offers these key benefits:

- Achieves concentricity or “product roundness” which greatly reduces material usage compared with other types of extrusion tooling
- Spiderless inline-designed heads results in no spider lines and allows room for more air – thus eliminating cold legs, which can inhibit product output
- Runs 1 to 5 layers simultaneously
- Engineered for a multitude of applications – including special fluoropolymer applications

A key Guill Tool technical highlight of the Series 900 is a patent-pending FeatherTouch™ adjustment in the die holder and a cartridge-style ball assembly that does not require the loosening of retaining screws to make adjustments. Additional unique benefits of the Series 900 include Guill’s Seal Right Systems, a positive seal, which eliminates leakage between deflectors, along with easy self-alignment that reduces operator error during assembly and is adaptable to a variety of specific extruder layout configurations.

“This series offers a standard platform design of the head with specific characteristics that are unique to individual applications included at no additional charge in the cost of the tooling. This is a tremendous benefit to a company that requires precision tooling with custom benefits at a standard off-the-shelf price. That certainly helps our customers’ bottom line,” says Tom Baldock, Guill Sales Manager.

Guill Tool also manufactures tips, dies, and breaker plates using state-of-the-art computerized CNC machining and EDM equipment. As well, engineering services using the latest CAD systems are available for custom-designing extrusion tooling product such as crossheads, tips, clamps, flanges, forming rolls, spiderless inline dies, dies, swing gates, breaker plates, special equipment and sizing dies.

Guill Tool received ISO certification in 1995. The first major extrusion tooling company to meet international standards, Guill Tool has long been recognized as one of the leading established designers and manufacturers of custom extrusion tooling for ap-

plications including wire, cable, fiber optics, medical tubing, wood composites, automotive tube, plastic compounding, custom applications, rubber, profile, industrial pipe, hose/tube, blow molding, plus food and packaging.

Guill Tool also encourages and provides education and training for the extrusion industry with plastic and aluminum model heads, fully illustrated operating manuals for step-by-step assembly and disassembly, training videos, and classes on the care and cleaning of extrusion tooling.

Founded in Rhode Island in 1962 by A. Roger Guillemette, Guill Tool was established as a job shop supplying tips, dies, cross-heads and replacement parts to the wire, cable or wire and cable, plastic and rubber industries in New England. Later, Guill Tool became a supplier for the entire United States and Canada, and today enjoys a worldwide market presence.

Technology in the Medical field is constantly evolving, and often requires an extensive array of Medical grade tubing in a variety of materials and thicknesses. Guill specializes in working with clients to design and manufacture Custom Extrusion Tooling to produce an unparalleled range of the highest quality Medical tubing in the industry. The company’s Micro Medical tooling can extrude tube thinner than a human hair, 0.008” or finer per revolution, and can be used to keep procedures as non-invasive as possible. Other models are used to produce tubing for feeding applications, including nasogastric and jejunal tubes.

► **Guill Tool & Engineering Co., Inc.**
10 Pike Street, West Warwick, RI 02893, USA
Tom Baldock, Sales Manager Extrusion, 挤压销售经理
www.Guill.com

制造ABS混合材料的新节能工艺

Extrusion Technology: New Energy-Efficient Process for Manufacturing ABS Blends



科倍隆的ZSK Mc18双螺杆挤出机在该系统中发挥着关键的核心作用，可以特别节能地制造ABS共混物
(图片:浙江智英石化科技有限公司)

Coperion's ZSK Mc18 twin screw extruder is playing a key central role in this system for particularly energy-efficient manufacturing of acrylonitrile-butadiene-styrene copolymer (ABS) blends (Photo: Zhejiang Zonepic Petrochemical Technology Co., Ltd.)

科倍隆 (Coperion) 为丙烯腈-丁二烯-苯乙烯共聚物(ABS)共混物料的特别节能制造开发出了一种工艺解决方案，科倍隆 ZSK Mc18双螺杆挤出机发挥了关键的核心作用。由于原料在ZSK挤出机中的停留时间短，产品加工温和，科倍隆的工艺解决方案生产出了非常高质量的ABS混合产品。ABS是一种热塑性工程塑料，结合了许多积极的机械性能和化学稳定性，使其在电气和汽车行业的多种用途中非常理想。

Coperion has developed a process solution for particularly energy-efficient manufacturing of acrylonitrile-butadiene-styrene copolymer (ABS) blends, with the Coperion ZSK Mc18 twin screw extruder playing a key central role. Thanks to short raw material residence time in the ZSK extruder and gentle product handling, Coperion's process solution achieves an extraordinarily high ABS blend product quality.

位于中国浙江省杭州市的浙江智英石化科技有限公司，是乳液接枝-本体聚合ABS共混法的技术许可方及工程公司，可生产通用级、食品级、阻燃级、电镀级ABS共混物。对于这种解决方案，公司已经许可使用多个ZSK 133 Mc18双螺杆挤

出机设计几套大型设施。两套系统已于近期投入生产:一套是位于李怀义利津炼化有限公司的年产200千吨级炼化装置，另一套是位于浙江石油化工有限公司的年产40千吨级炼化装置。

ZSK挤出机的最大能源效率

ABS共混物由合成橡胶聚合物HRG和SAN(苯乙烯-丙烯腈)组成。科倍隆为制造ABS混合料开发了一种特别节能的工艺解决方案。ABS乳剂在生产后从反应器中湿滑而出。在科倍隆的解决方案中，仍然是潮湿的HRG通过下游科倍隆 ZS-B侧给料机引入到下游ZSK挤出机的工艺段之前，先通过螺旋压机。这样就免除了ABS的能量密集型预热干燥。采用称重型科倍隆 K-Tron喂料机，将SAN（丙烯腈）和添加剂同样地引入ZSK挤出机。SAN，添加剂和HRG（苯乙烯）在ZSK挤出机的加工段集中均匀地混合，同时非常温和地进行加工，因此产品不发黄，聚合物也不会分解。与传统制造工艺相比，科倍隆的解决方案的能耗显著降低。此外，剩余单体的部分减少到绝对最小值。

科倍隆工艺技术与研发部总经理Frank Lechner坚信科倍隆这一进步的重要性：“我们很自豪地看到浙江智英石化科技有限公司的这两套大型装置成功地接管了ABS混合材料的生产。这些机器已经在每天证明着它们的运行是多么节能。与此同时，他们提供了持续的、极高的产品质量，强调了我们的创新工艺开发如何精确地满足客户的要求。我们的最新开发成果，为进一步减少ABS生产的能源消耗提供了一种方法，已经引起了极大的兴趣。我们制造的ABS混合物料可以直接接触食品解决方案也是如此。”

ABS is a thermoplastic engineering plastic which combines numerous positive mechanical properties and chemical stability, which make it ideal for multiple uses in the electric and automotive industries.

Technology licensing and engineering company Zhejiang Zonepic Petrochemical Technology Co., Ltd. located in Hangzhou City, Zhejiang Province, People's Republic of China, is a licensor for the emulsion grafting-bulk polymerization ABS blend method which allows for the production of ABS blends in general grade, food grade, flame retardant grade and electroplating grade. For this solution the company has permitted to design several large installations with multiple ZSK 133 Mc18 twin screw extruders. Two systems have recently started production: one plant is at Lihuayi Lijin Refining & Chemical Co. Ltd. with an output of 200

KTA, and the other at Zhejiang Petroleum & Chemical Co, Ltd. with an output of 400 KTA.

ZSK Extruders for maximum energy-efficiency

ABS blends consist of synthetic rubber polymers HRG and SAN (styrene-acrylonitrile). Coperion has developed a particularly energy-efficient process solution for manufacturing ABS blends. The ABS emulsion emerges wet from a reactor following its manufacture. In Coperion's solution, it passes through a screw press before the HRG – still damp – is introduced downstream via a Coperion ZS-B side feeder into the process section of a ZSK extruder. The energy-intensive thermal pre-drying of the ABS is thus eliminated.

Using gravimetric Coperion K-Tron feeders, SAN and additives are likewise introduced into the ZSK extruder. SAN, additives and HRG are intensively and homogeneously mixed in the ZSK process section, all the while handled very gently, so that the product does not yellow, nor does the polymer break down.

In comparison to conventional manufacturing processes, Coperion's solution operates with markedly lower energy consumption. Moreover, the portion of residual monomers is reduced to an absolute minimum.

Frank Lechner, General Manager of Process Technology and Research & Development at Coperion, is convinced of the importance of Coperion's development: "We're proud to see how both of these large installations from Zhejiang Zonepic Petrochemical Technology Co., Ltd. have successfully taken over production for ABS blends. These machines are already proving on a daily basis how energy-efficient their operation is. At the same time, they deliver a constant, extremely high product quality that underscores how our innovative process development precisely meets our customers' requirements. Even our newest development, providing a way to further reduce ABS production's energy consumption, has already met with great interest – as has our solution for manufacturing ABS blends for direct contact with food products."

► Coperion GmbH

Theodorstr. 10, 70469 Stuttgart, Germany
www.coperion.com

科倍隆开发出了一套围绕ZSK Mc18双螺杆挤出机的工艺，用于制造ABS混合料，该工艺的能源效率明显高于传统工艺，同时提供恒定的、非常高的产品质量(照片：科倍隆，德国斯图加特)

Coperion has developed a process, built around the ZSK Mc18 twin screw extruder, for manufacturing ABS blends that operates markedly more energy-efficiently than conventional processes while delivering constant, very high product quality (Photo: Coperion, Stuttgart Germany)

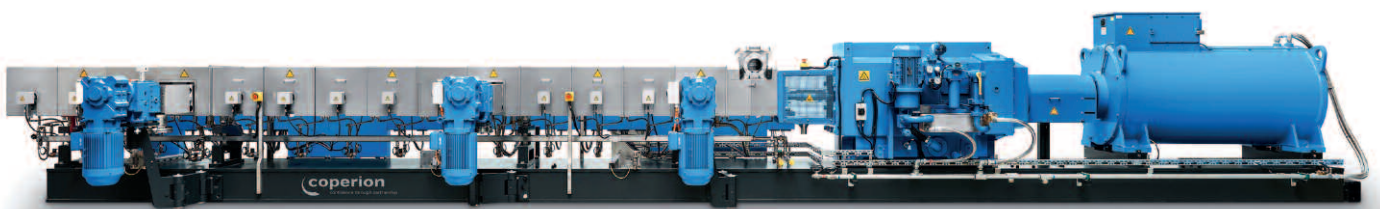

配有最新设计MDO单元的新型多功能流延薄膜生产线

Film Extrusion: Latest Version of Multi-Purpose Cast Film Line with New MDO Unit



SML在其技术中心安装一条新型多功能流延薄膜生产线。该生产线的通用性好，拥有多项技术创新，其中最为重要的是经进一步开发的MDO单元。

SML has set up the newest version of its multi-purpose cast film line in its Technology Centre. The line is universally applicable and features a number of technical innovations: Above all, a further-developed MDO unit.

SML的研发工程师 Elias Mayrhofer自豪地评论：“我们的新型多功能流延薄膜生产线甚至让业内专家印象深刻。该生产线的技术性能几乎可以满足所有客户在流延薄膜生产中的要求。”流延薄膜生产线可用于生产CPP、CPE和流延PET薄膜以及阻隔膜和单向拉伸膜。流延薄膜的应用领域广泛：从金属化薄膜和标准复合食品及非食品包装薄膜，到易回收的MOPE自立袋薄膜，再到标签膜，还包括电缆绝缘膜和易撕MOPP薄膜等工业产品。尽管其有多种功能和应用，该生产线还可经进一步优化以生产专业产品，确保生产效率最高和质量最佳。

连贯性概念

Elias Mayrhofer表示：“我们所有机械设备的核心特征是我们不断开发和优化的生产线连贯性概念。”SML多功能流延薄膜生产线现代和清晰的设计再次强调了这一点。SML的新型多功能流延薄膜生产线具有下列技术特点：

- 五台挤出机用于加工PP, PE, PA, PET, EVOH和粘合材料

- 可调几何设计的七层分流道，可提供多种不同层次结构
- 模头宽度为2,850 mm，配有内腔调幅装置，每边调节范围为350 mm
- 新型MDO单元：辊筒最高温度为160 °C，最大拉伸比为1:10
- 卧式滑轨收卷机可收卷4个分切膜卷

加工单材质的MDO单元

SML新型流延薄膜生产线的一项重要创新是MDO单元，该装置也是为生产易回收的MOPP、MOPE和MOPET等单材质薄膜而设计的。凭借这一MDO单元，薄膜沿生产方向的强度、挺度和抗穿刺等性能得到进一步提高，同时薄膜厚度和沿生产方向的伸长率显著降低。SML简化了整个MDO工艺：简单明了的设计提高操作舒适性的同时，为维护提供了足够的空间，方便设备检修。

新型辊筒排布 – 拉伸间隙更小

SML最新MDO单元的主要技术特点之一，是优化工艺的辊筒排列。拉伸间隙以电动方式调节，这使得操作和更换产品非常简便快捷。由于拉伸辊的直径为220 mm，拉伸间隙可保持在50和220 mm之间（薄膜在辊筒间的自由长度）的狭窄范围内，拉伸辊之间的距离可降低到仅为几毫米。拉伸区压辊的位置也可调节，这确保了薄膜的理想拉伸过程，不受拉伸间隙的影响。

SML新型人机界面实现轻松设置

最后，MDO单元的所有工艺参数均可实现数字化记录，可通过SML的新型人机界面轻松设置和调节。

SML的新型多功能流延薄膜生产线可供客户试用和生产样品。

“Our new multi-purpose cast film line will not fail to impress even long-serving experts. The line has the technical capacity to fulfil almost every customer requirement in cast film production”, Elias Mayrhofer, R&D Engineer at SML, comments with pride. The cast film line is ready for the production of CPP, CPE, Cast-PET, barrier, as well as for mono-oriented films. The application areas are comprehensive as well: They range from film for metallised and laminated standard food and non-food packaging to easy-to-recycle stand-up pouches of MOPE film and

further to label film, and also include technical products like cable insulations and easy-tear MOPP film. Despite its wide functional range, the line can be further optimised for the manufacturing of specialised products – assuring the highest efficiency and maximum quality.

Coherent concept

“A central characteristic of all of our machinery is the coherent line concept that we continue to develop and optimise,” Elias Mayrhofer states. This is underlined yet again by the modern and clear design of SML’s multi-purpose cast film line, which offers the following technical features:

- Five extruders for the processing of PP, PE, PA, PET, EVOH, as well as adhesives
- A seven-layer variable geometry feedblock with the possibility of numerous different layer arrangements
- Die width 2,850 mm, with internal decking system two times 350 mm
- New MDO unit: maximum roll temperature of 160 ° C, maximum stretching ratio 1:10 Horizontal sliding winder for up to 4 part bobbins

MDO unit for mono-materials

One key innovation featured in SML’s latest cast film line is the MDO unit, that is also designed for the manufacturing of easy-to-recycle mono-material films such as MOPP, MOPE and MOPET. With this MDO unit, properties such as the film strength in the machine direction, stiffness and puncture resistance are increased even further, while the film thickness and elongation in the machine direction are significantly decreased.

SML has streamlined the whole MDO process: The clean and straightforward design makes operation comfortable and provides sufficient space for maintenance offering easy access.

New roller arrangement – tight stretching gap

One of the main technical features of SML’s latest MDO version is the process-optimised roller-arrangement. The adjustment of the stretching gap takes place in a motorised fashion, making the operation and alternations for product changes quite simple. As the stretching rollers have a diameter of 220 mm, the stretching gap can be kept narrow in a range between 50 and 200 mm (free length of the film between the rollers). While the distances between the stretching rollers can be reduced to a few mm only. The positions of the nip rollers in the stretching area are adjustable too. This ensures an ideal stretching process of the film, independent of the defined stretching gap.

Comfortable settings with SML’s new HMI

Finally, all the process parameters of the MDO unit are digitally recorded and can be comfortably set and adjusted with SML’s new HMI.

SML’s new multi-purpose cast film line is available to customers for trials and sample production.



► SML Maschinengesellschaft mbH
Gewerbepark Ost 32, A-4846 Redlham, Austria
Elias Mayrhofer, mel@sml.at, www.sml.at

从转换加工到全系列供应商

Flat Film Extrusion – Case Study: From Converter to Full-Range Supplier

JaeKwang是韩国最知名的包装制造商之一。该公司以前只从事转换加工业务，去年决定进军新方向，将薄膜制造业务掌握在自己手中。这对JaeKwang来说是迈出了一大步，该公司现在是韩国第一家采用5层工艺生产CPP平面薄膜的公司。

JaeKwang is one of the best-known packaging manufacturers in South Korea. The company, which previously operated exclusively as a converter, decided last year to strike out in a new direction and take film production into its own hands. This was a big step for JaeKwang, which is now the first company in South Korea to produce CPP flat films in a 5-layer process.

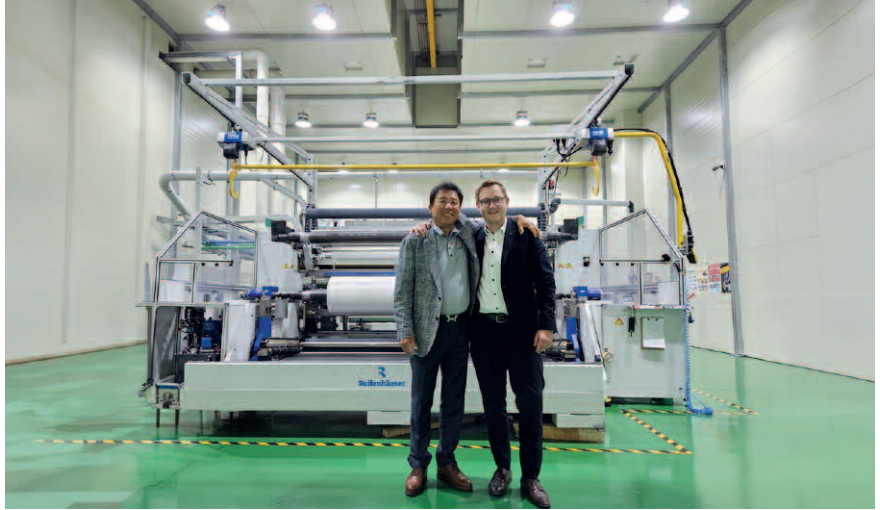

“JaeKwang”首席执行官Hong-Soo Kang,、“莱芬豪舍”地区销售经理Benjamin Pott (从左至右)

Hong-Soo Kang, CEO at JaeKwang and Benjamin Pott, Area Sales Manager at Reifenhäuser (from left to right)

去年秋天，JaeKwang安装了第一条由Reifenhäuser（莱芬豪舍）提供的5层CPP薄膜生产线，这是一个里程碑，而且不仅仅是在JaeKwang。毕竟，这是韩国国内同类产品中的第一条。为了使自己独立于供应商，这家成立于1999年的公司决定未来尽可能多地在内部生产。“我们渴望制造过程中在采用尽可能多的自有工艺过程。在这样做的过程中，我们有非常高的质量标准，1300公斤/小时的高质量标准和强大的产能也是公司投资的原因。”JaeKwang首席执行官Hong-Soo Kang解释说。

单独配置的生产线，有着最高的产量

非凡的生产力来自于对满足韩国特定市场和原材料所要求的技术指标。在认识到这一关键要求方面，Reifenhäuser和JaeKwang确保CPP机器已进行了量身定制，以满足最终产品的最佳要求。由于莱芬豪舍在热塑材料挤出设备方面的核心竞争能力，莱芬豪舍团队能够完全满足客户和当地原材料的要求。

JaeKwang的所有者兼首席执行官Kang先生说：“我们很高兴有莱芬豪舍作为我们的强大合作伙伴。”Kang继续说道：“这条生产线是专门为满足我们的要求而设计的，它使我们能够在保持相同的高质量和功能的同时，实现很大的高产量，从而为我们在市场上提供决定性的竞争优势。”

在技术上，令JaeKwang信服的是莱芬豪舍的feedblock共挤适配器系统。JaeKwang选择了专业版共挤适配器。这使得可以在极低的厚度公差下生产多层薄膜，并在生产过程中调整各层的分布。JaeKwang的Kang先生赞扬道：“feedblock共挤适配器使我们能够尽可能灵活地测试和实施新配方，而不必接受原材料的巨大损失。”因此，韩国这家全能型公司现在委托莱芬豪舍公司安装第二条生产线。

带拉伸装置的生产线在韩国尚属首例

在韩国，包装材料在触感和外观上都进行了创造性的精心设计。此外，消费者对功能的需求也在不断增长。例如，目前，被称为易撕裂功能在制袋行业的需求尤其大。

由于具有易撕裂功能，任何类型的袋子都可以快速、安全、洁净地打开，这得益于一条自带的撕裂条。这个使用方便的解决方案可以通过一条带有拉伸单元(机器方向拉伸，MDO)的生产线来实现，现在，JaeKwang将在下一步安装MDO。这种设备技术在韩国也是首次推出。

莱芬豪舍的区域销售经理Benjamin Pott解释说：“我们很高兴在JaeKwang找到了合作伙伴，我们可以积极支持其创新产品的开发。JaeKwang也对双方重新合作感到高兴。Kang先生补充说：“莱芬豪舍的专业知识和技术帮助我们在市场上稳步增长，并以我们的产品为消费者创造明确的附加价值。”

Last autumn, JaeKwang installed the first 5 layer CPP film line from Reifenhäuser – a milestone, and not only for JaeKwang. After all, it is the first line of its kind ever in the country. In order to make itself independent of suppliers, the company, founded in 1999, decided to produce as much as possible in-house in the future. "We are keen to take on as many steps as possible in the manufacturing process ourselves. In doing so, we have very high quality standards," explains Hong-Soo Kang, CEO at JaeKwang. The high quality standard and the strong production output of the line of 1300kg/hour were also what convinced the company to make this investment.

Top output values thanks to individual line configuration

The remarkable productivity results from a technological focus on meeting the specific South Korean market and raw material requirements. In recognition of this crucial aspect, Reifenhäuser and JaeKwang have ensured that the CPP machine has been tailored to meet the optimum requirements of the end product. Thanks to Reifenhäuser's core competencies in the hot part extrusion equipment, the Reifenhäuser team was able to fully align the line with the needs of its customer and the local raw materials.

"We are pleased to have Reifenhäuser as a strong partner at our side," said Owner & CEO Mr. Kang at JaeKwang. "The line, which was specially designed to meet our requirements, enables us to achieve an enormously high throughput while maintaining the same high quality and functionality, thus offering us a decisive competitive advantage in the market," Mr. Kang continues.

Technologically convincing for JaeKwang was in particular the feedback system from Reifenhäuser. JaeKwang opted for a Co-extrusion Adapter Pro. This enables multilayer production in ex-

tremely low tolerances and adjustment of the layer distribution during ongoing production. "The feedback enables us to test and implement new recipes as flexibly as possible without having to accept high raw material losses," praises Mr. Kang at JaeKwang. The Korean all-rounder has therefore now commissioned Reifenhäuser to install a second line.

Line with stretching unit is the first of its kind in South Korea

In South Korea, packaging materials are designed creatively and elaborately in terms of haptics and appearance. In addition, there are growing consumer demands for functionality. Currently, for example, the so-called Easy Tear function is particularly in demand for pouches.

With the Easy Tear function, any type of pouch can be opened quickly, safely, and cleanly thanks to an integrated tear strip. This user-friendly solution can be realized by a line with a stretching unit (MDO), which JaeKwang will now install in the next step. This plant technology will also be the first of its kind in South Korea.

"We are very pleased to have found a partner in JaeKwang that we can actively support in its innovative product developments," explains Benjamin Pott, Area Sales Manager at Reifenhäuser. JaeKwang is also pleased about the renewed cooperation. "Reifenhäuser's know-how and technologies help us to grow steadily in the market and to create clear added value for consumers with our products," adds Mr. Kwang.

Reifenhäuser Gruppe

Spicher Str. 46, 53844 Troisdorf, Germany
www.reifenhäuser.com

莱芬豪舍 物有所值的 CPP 5层CPP
生产线安装在韩国最知名的包装制造
商之一的JaeKwang
(图片:Reifenhäuser)

*Reifenhäuser Value CPP 5-layer
line at JaeKwang, one of the
best-known packaging manufactu-
rers in South Korea
(Pictures: Reifenhäuser)*



www.smart-extrusion.com

采访 ECON 集团 C 级高管

An Interview with C-Level Management of the ECON Group



Gerhard Hehenberger
(首席执行官 / CEO)



Dominik Neumann
(研发总监 / Head of R&D)



Stefan Schedlik
(首席技术官 / CTO)



Gerhard Hemetsberger
(首席战略官 / CSO)

Pellet Vision 采用了怎样的开发方法？

What was the development approach for the Pellet Vision?

Gerhard Hehenberger (首席执行官)：以客户为导向的创新是 ECON 的首要任务。几年前，我们在 K 2019 上首次展出了 Pellet Vision，彰显了我们在自动和自优化水下造粒方面的远见。与此同时，我们进一步开发了此系统，使其具备批量生产能力，并成功应用于部分客户。

Gerhard Hehenberger (CEO): Customer-oriented innovation is ECON's top priority. With the first presentation of the Pellet Vision in 2019, we already emphasized our visionary approach towards automatic and self-optimizing underwater pelletizing (UWP) several years ago. In the meantime, we have further developed the system to series production readiness and it is already being used very successfully by some customers.

您能给我们简单介绍一下工作原理吗？

Can you explain the operating principle in a few words?

Dominik Neumann (研发总监)：简而言之，就是将生产出的颗粒与目标颗粒的形状和尺寸进行比较。不过，由于市场上没有适合的软件，我们自主开发了评估颗粒质量的软件和算法。具体来说，就是在生产过程中将颗粒的形状和大小与目标颗粒进行随机比较（例如每 10 分钟一次）。对偏差进行统计检测，然后向任何界面（水下造粒机器人界面、挤出机器人界面、过程控制站等）发送警告和可视化信息。

Dominik Neumann (Head of R&D): Simply put, the pellets produced are matched with the shape and size of the target pellets. However, since no suitable software is available on the market for our purposes, we have developed software and algorithms for evaluating the pellet quality ourselves. In detail, this means that the shape and size of the pellets in the production process are randomly compared (e.g. every 10 min) with a target pellet. Deviations are detected statistically and then a warning and visualization are transmitted to any interface (HMI of the UWP, HMI of the extruder, at the process control station, etc).

系统能为客户带来哪些好处？

What customer benefits does the system offer?

Stefan Schedlik (首席技术官)：通过提前检测颗粒几何形状的变化，我们的客户可以获得稳定一致的颗粒质量，同时最大限度地减少不合格的材料。由于 Pellet Vision 还能检测变化的原因，如上游区域的工艺波动，因此机器操作员可以有针对性地进行干预，节省时间。在向全自动系统发展的过程中，也不再需要人工取样。另外，还可在现有设备上加装 Pellet Vision 系统。

Stefan Schedlik (CTO): By detecting changes in pellet geometry early, our customers achieve a stable and consistent pellet quality while minimizing off-spec material. Since Pellet Vision also detects the cause of changes, such as process fluctuations

in the upstream area, the machine operator can intervene in a targeted and time-saving manner. In the direction of fully automated systems, personal sampling is also no longer necessary. Incidentally, the Pellet Vision can also be retrofitted on existing systems.

ECON 的未来会怎样？

What does the future hold for ECON?

Gerhard Hemetsberger (首席战略官)：客户高度满意的反馈激励我们进一步开发 Pellet Vision，使其成为水下造粒的全自动自优化系统。通过这种方式，机器可以自我控制和优化，通过调整速度、接触力、温度等工艺参数，自动纠正颗粒偏差。无论客户的未来发展方向如何，ECON 已通过我们的手动操作和智能系统组合实现了最佳定位。

Gerhard Hemetsberger (CSO): The highly gratifying feedback from our customers motivates us to continue to develop the Pel-

let Vision into a fully automatic self-optimization of the UWP. The machine thus controls and optimizes itself, with pellet deviations being corrected independently by adjusting process parameters such as speed, contact pressure, temperatures, etc. Regardless of the future direction of our customers, ECON is already well positioned with our portfolio of manually operated and intelligent systems.

感谢您接受我们的采访。

Thank you for this interview.

► **ECON GmbH**
Biergasse 9, 4616 Weißkirchen, Austria
www.econ.eu

MEDIA DATA 2024
MAGAZINE · WEBSITE · NEWSLETTER

EXTRUSION

EXPERT MEDIA ON PLASTICS EXTRUSION

Germany UK USA China

EXTRUSION
motan
GRAYCOLOR 110 med
Damen- und Mischgäste für den Einsatz in der Pharma- und Medizintechnik.

EXTRUSION INTERNATIONAL
02/2023
Solutions for circular economy – eXtrudEX series
The innovative way of pelleting extrusion
www.bursterfeld-technik.com

EXTRUSION INTERNATIONAL USA
01/2023
Guill
WORLD LEADER IN EXTRUSION TOOLING
Process engineering for efficient plastics extrusion of composites

挤塑 EXTRUSION ASIA EDITION

VM Verlag GmbH Cologne/Germany
www.smart-extrusion.com

期待已久，CHINAPLAS 时隔六年重返上海 业界对2024年国际橡塑展的预期不断上升

Long-awaited Return to Shanghai after Six Years Rising Expectations to CHINAPLAS 2024 from the Industry

■ 中国经济正显示出快速复苏的迹象，而亚洲则成为全球经济的火车头。随着经济持续好转，被视为经济晴雨表的会展业也出现了强劲的恢复势头。继2023年的精彩表现之后，本届国际橡塑展将于2024年4月23日至26日在上海虹桥国家会展中心(NECC)全部15个展馆举行，展览面积超过38万平方米。它将接待来自世界各地的4000多家参展商。脱碳和高价值利用的市场趋势正在为塑料和橡胶行业的高质量发展创造机遇。作为亚洲位居第一的国际橡塑展将全力推动行业高端化、智能化、绿色化发展。该展览在缺席6年后强势回归上海，在中国东部的塑料和橡胶行业中保持了对这次团聚的期待。

工业是宏观经济的基石和稳增长的前沿。从2023年6月2日起，区域全面经济伙伴关系协定RCEP在菲律宾正式生效，标志着RCEP在所有15个签署国之间全面实施。该协议允许分享经济发展的利益，并加强全球贸易和投资的增长。对大多数RCEP成员国来说，中国是其最大的贸易伙伴。2023年上半年，中国与RCEP其他成员进出口总额达6.1万亿元人民币(约合8350亿美元)，对中国国际贸易增长的贡献率超过20%。此外，随着“一带一路”倡议推出十周年，对基础设施和制造业的需求迫切，“一带一路”沿线的市场潜力蓄势待发。

展会主办方的全球买家团队在海外市场的访问中获得了积极的反馈。许多来自不同国家和地区的商业协会和企业都对2024年国际橡塑展表示了期待和支持，并已开始组织代表团参加这一年度大型活动。

抓住中国市场的新机遇:在外贸反弹的同时，国内需求也在强劲复苏。近年来，中国制造业一直在努力实现高质量发展、高附加值、智能制造。其中，中国工业和信息化部联合相关部门发布了化工、建材、汽车、轻工、电子信息制造业等十大重点行业的强劲增长计



划。大力推动新能源汽车、智能家电、绿色建材、高端医疗设备、机器人等创新产品在农村的应用。

举办2024年国际橡塑展的上海市发布了三年(2023-2025年)行动计划，以促进全市制造业高质量发展，加强制造业对全市整体经济发展的支持作用，制造业占地区GDP的

产业转型升级加快，新动力更加凸显。国际橡塑展的组织者雅式展览服务有限公司的总经理梁雅达(Ada Leung)说：“今年，在我们与塑料和橡胶供应商的沟通中，我们明显感觉到，无论是海外公司还是本地公司，都对中国市场充满信心，并对在中国开拓商机非常乐观。”是时候向世界展示创新产品和技术了：2024年国际橡塑展对展位的巨大需求表明，随着经济的复苏，塑料和橡胶行业的信心也在恢复。“预订展位、展示能力、捕捉商业机会、建立品牌知名度”已成为参展商在后大流行时代展示其优势的必做清单。为响应行业参展需求，展会展区

面积较2018年上海同场馆展区增长超过11%。

在展会扩大期间，预计将有更多多样化的展品以及参展商出现在博览会的场地上。国际参展商正在热情地返回展会，预计欧洲展馆将恢复大流行前的规模。中国的国有企业和民营企业，包括“专业化、精细化、特色化、创新化”(PRSI)企业和“小巨人”公司，将在舞台上共同发光。这些工业领袖正在带来突破性技术，并展示自主创新的无限潜力。塑料和橡胶工业的技术发展迅速，其应用不断扩大和发展。超过4000家参展商，来自不同应用领域的专业贸易买家将找到各种先进、环保的解决方案和智能制造技术，以探索创新，提高技能，提高效率，快速响应市场需求。技术创新是塑料橡胶工业高质量发展的“金钥匙”。

网上预约报名开放：梁小姐说道：“2023年，国际橡塑展在展区面积和参展观众方面创出了历史新高。这给了我

们很大的信心和决心。随着市场对展会的需求和期待的积累，回归上海对我们来说意味着一个全新的开始和全新的旅程。在新的一年里，我们将努力为塑料橡胶行业举办一场精彩的年度盛会。期待在上海举办的国际橡塑博览会上与大家见面，共同推动塑料橡胶工业的高质量发展。”回到上海对我们来说意味着一个新的开始，一个全新的旅程。在新的一年里，我们将努力为塑料橡胶行业举办一场精彩的年度盛会。期待在上海举办的国际橡塑博览会上与大家见面，共同推动塑料橡胶工业的高质量发展。”

更多信息或查询请登录：
www.ChinaplasOnline.com

■ China's economy is showing signs of quick recovery while Asia acts as the locomotive of the global economy. As the economy continues to rebound, the exhibition industry, which is regarded as an economic barometer, is experiencing a strong recovery. Following its impressive performance in 2023, **CHINAPLAS 2024** will be held from **April 23 - 26, 2024**, occupying all 15 exhibition halls of the National Exhibition and Convention Center (NECC) in Hongqiao, **Shanghai, PR China**, with a total exhibition area of over 380,000 sqm. It is ready to receive more than 4,000 exhibitors from around the world.

The market trends of decarbonization and high-value utilization are unlocking the golden opportunities for the high-quality development of the plastics and rubber industries. As Asia's no. 1 plastics and rubber trade fair, CHINAPLAS will spare no efforts to promote the high-end, intelligent, and green development of the industry. The exhibition is making a strong comeback to Shanghai after a six-year absence, upholding the anticipation within the plastics and rubber industries for this reunion in Eastern China.

The industrial sector is the cornerstone of the macro-economy and the frontline for stable growth. Starting from June 2, 2023, the Regional Comprehensive Economic Partnership (RCEP) officially took effect in the Philippines, remarking the full implementation of RCEP among all 15 signatories. This agreement allows for the

sharing of economic development benefits and reinforcing the growth of global trade and investment. For most RCEP members, China is their largest trading partner. In the first half of 2023, the total import and export volume between China and other RCEP members reached RMB 6.1 trillion (USD 8,350 billion), contributing over 20% to China's international trade growth. In addition, as the "Belt and Road Initiative" celebrates its 10th anniversary, there is a pressing demand for infrastructure and manufacturing industry, and the market potential along the Belt and Road routes is poised for development.

The global buyer team of the show organizer has received positive feedback during their visits to overseas markets. A number of business associations and companies from various countries and regions have expressed their anticipation and support for CHINAPLAS 2024, and have started organizing delegations to join this annual mega event.

Seizing New Opportunities in China's Market: Besides the rebound of foreign trade performance, domestic demand is also seeing a strong recovery. In recent years, China's manufacturing industry has been striving for high-quality development, high value-added and smart manufacturing. Among them, the Ministry of Industry and Information Technology in China, in collaboration with relevant departments, has released robust growth plans for ten key industries, including chemicals, building materials, automobiles, light industry, and electronic informa-

tion manufacturing industry etc. It imperatively promotes the application of innovative products such as new energy vehicles, smart home appliances, green building materials in rural areas, high-end medical equipment, and robotics.

Shanghai, holding for CHINAPLAS 2024, has released a three year (2023-2025) action plan to promote the high quality development of the city's manufacturing industries, and strengthen of the manufacturing industry's role in supporting the overall economic development of the city, accounting for over one-fourth of the regional GDP.

The industrial transformation is accelerating, and new impetus is becoming more prominent. "This year, during our communications with plastics and rubber suppliers, we evidently felt that both overseas and local companies have vast confidence in the Chinese market and are very optimistic about exploring business opportunities in China," said Ada Leung, General Manager of Adsale Exhibition Services Ltd., the organizer of CHINAPLAS.

Time to Show-off Innovative Products and Technologies to the World: The immense demand of exhibition booths in CHINAPLAS 2024 shows that the confidence of the plastics and rubber industries has recovered just like the economy does. "Reserving booths, showcasing capabilities, capturing business opportunities, and building brand awareness" have become the must-do list of exhibitors to demonstrate their strengths in the post pandemic era. In response to the exhibiting demand from the industry, the exhi-





Leading material suppliers and recycling equipment manufacturers will showcase their solutions at CHINAPLAS 2024 to support the industry's sustainable development goals

Exhibition area will increase by over 11% compared with the show in 2018 at the same venue in Shanghai. During the expansion of the show, it is expected to have a more diverse range of exhibits in the fairground, as well as exhibitors. International exhibitors are returning to the exhibition enthusiastically and European pavilions are foreseen to regain their pre-pandemic scale. State-owned enterprises and private companies in China, including "Professionalization, Refinement, Specialization and Innovation (PRSI)" enterprises and "Little Giant" companies, shall shine together on the stage. These industrial leaders are bringing breakthrough technologies and showcasing limitless potential for independent innovation. The technologies of plastics and rubber industries have evolved rapidly, with its applications continuously expanding and developing. With over 4,000 exhibitors, professional trade buyers in different application sectors will

find a variety of advanced and environmentally friendly solutions as well as intelligent manufacturing technologies for the exploration of innovation, skill enhancement, efficiency improvement, and rapid response to market demands. Technological innovations, serving as the "golden key", will foster the high-quality development of the plastics and rubber industries.

Online Pre-registration is Open: "In 2023, CHINAPLAS has reached a new record high in terms of exhibition area and no. of visitors, giving us great confidence and determination. With the accumulated market demands and expectations for the show, returning to Shanghai means a fresh start and brand-new journey to us. As we enter another crucial year, we will strive to present a splendid annual event for the plastics and rubber industries. Look forward to meeting you all in CHINAPLAS 2024 in Shanghai and jointly promoting the high-quality development



of the plastics and rubber industries," said Ms. Leung.

For more information or enquiries:

➔ **Adsale Exhibition Services Limited**
www.ChinaplasOnline.com

CHINAPLAS 2024 is ready to accommodate more international visitors in Shanghai. Exhibitors shall undoubtedly expect to discover and seize more new business opportunities on the fairground



经验与质量的完美结合

Experience Meets Quality

提到高效安全地处理聚酯PET废料，毫无疑问 EREMA拥有宝贵的经验。早在25年前，这家奥地利专业开发制造塑料再生设备的企业就开始探索瓶子的再利用。在过去三年里，EREMA用于瓶片再生的设备有将近一半都安装在了亚洲。食品级回收在当地越来越被重视，而纺织领域也日益被开拓。EREMA系统提供最高的质量标准，不仅符合全球公认的欧洲和北美食品安全当局的严格限制，而且完全满足全球品牌商的严格要求。在2024年4月23日至26日于上海举行的国际橡塑展上，EREMA专家将与感兴趣的参观者分享他们的专业知识。

随着 PET 行业的发展，尤其是在亚洲和非洲，对 PET 废料回收解决方案的需求也相应增加。EREMA中国公司总经理James Qiu表示：“我们为各类运用度身定做设备，包括食品级运用。核心关键是久经考验的 VACUREMA®，此项专利技术于 25 年前被推出，之后持续开发完善。目前，全球有 400 多套不同技术版本的食物级 PET 系统（如 VACUREMA® Basic、Advanced、Prime 或 MPR 以及 VACUNITE®）在使用，年总产量超过 400 万吨。仅在过去三年中，EREMA 就为“瓶子”行业提供了 100 套系统。其中近 60% 是瓶到瓶解决方案。其余的则用于瓶到片材、到PET 捆扎带和一度增长的瓶到纤维领域。

挤出前就已净化

为了从不同质量的进料中生产出符合食品安全、外观无瑕疵的 rPET 粒子，可靠的回收性能是一个必须。VACUREMA® 系统的关键优势在于真空反应器中的 SafeFlake（安全瓶片）技术。它集净化、干燥和 IV 处理于一体。通过在真空和适当温度下对 PET 片材进行预处理，可在挤出前有效去除水分和迁移物质。这可以防止熔体在挤出机中发生水解和氧化降解。即使进料的水分、混合或体积密度等参数发生变化，再生粒子的质量也能始终保持在高水平。

除了质量方面的原因，还有经济方面的原因支持此回收工艺。购置和使用的总成本（即总拥有成本）以及能耗都相对较低。“VACUREMA® Prime 系统的总能耗仅为 0.295 kWh/Kg。与市场上流通的 PET 再生线相比，这是一个最佳的能效值”，EREMA 公司瓶业务部开发经理 Christoph Wöss 说。VACUREMA® Prime 是该基本工艺的深入变体，在此技术中，两台结晶干燥机位于真空反应器之前，以间歇模式运行，同

When it comes to the efficient and safe processing of PET waste, EREMA can draw on valuable experience. The bottle systems made by the Austrian recycling machine manufacturer have 25 years of proven experience on the market. Almost half of the bottle systems shipped in the past three years have been installed in Asia. The production of food contact compliant rPET is becoming increasingly important there – also in the textile industry. EREMA impresses with the highest quality standards and not only easily undercuts the strict limit values of the European and North American authorities for food safety recognised worldwide, but also meets the specifications of global brands. At Chinaplas in Shanghai from 23 to 26 April, 2024, EREMA experts will be on hand to share their expertise with trade fair visitors interested in recycling.

VACUNITE® 系统- EREMA成熟的 VACUREMA® 技术与 Polymetrix 的真空辅助氮气 SSP 相结合

VACUNITE® systems see EREMA combine proven VACUREMA® technology with the vacuum-assisted nitrogen SSP from Polymetrix



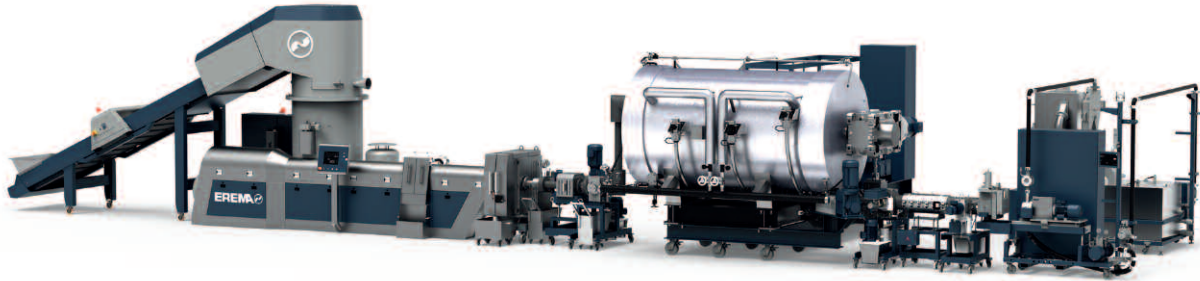

EREMA开发了INTAREMA® FibrePro:IV，用于纤维到纤维的回收，以满足纺织业的特殊要求

EREMA has developed INTAREMA® FibrePro:IV specifically for fibre-to-fibre recycling to meet the requirements of the textile industry

样在真空条件下交替进行去污处理。通过在瓶片上进行固态缩聚（SSP）来提高粘度（IV）。

VACUNITE® 带来双重保障

基于法规要求和知名品牌商自发的公开承诺，PET 瓶等产品生产中的回收料混合比例正在显著增加。“尽管因此导致的进料质量不断下降，但回收设备必须保持生产出更好的再生出料。” Christoph Wöss 解释说，“VACUNITE® 能满足这个要求”。与瑞士Polymetrix 合作，EREMA在其基础VACUREMA® 工艺上，进一步开发了氮气环境下的真空辅助SSP。所有热加工步骤均在氮气和/或真空环境下进行。

对用户而言，基本工艺的“安全瓶片”和挤出造粒之后的再次净化意味着双重安全。Christoph Wöss 总结道：“通过VACUNITE®，我们为瓶到瓶客户提供了一项先进的技术，在从技术性能到回收质量的各个层面都设立了新的标准。”在SSP 中使用的氮气经过净化后再反馈到上游工艺步骤中，从而降低了氮气的总体消耗量。VACUNITE® 的另一个优点是提高了色值。“我们可以在瓶子多个循环周期后仍旧保持透明度，使瓶到瓶实现真正的循环经济。”

食品安全型 rPET 在纺织业的应用日益增多

除食品行业外，食品级 rPET 在纺织行业也发挥着重要作用。知名品牌越来越关注符合食品级要求的再生 PET 原料，目标是为客户提供对健康无害的可持续纺织品。这一运用在 EREMA的VACUREMA工艺在纤维应用的销售额上得到体现，而亚洲是这一领域的重要市场。

普遍而言，纺织业对 PET 回收利用的重要性与日俱增。全球PET 总量的约三分之二用于生产合成纤维。为此，EREMA建立了自己的纤维和纺织品业务部。

对纤维进行温和的材料处理

INTAREMA® FibrePro:IV 设备是专为纤维到纤维的回收而开发的。通过将成熟的 INTAREMA® 技术与新型 IV 优化器相结合，将受纺丝油严重污染的 PET 纤维碎料，转换为可再次生产出最细密纤维的再生粒子。该系统的特点是在真空环境中对熔体进行有针对性的表面活性更新，与传统的 PET 回收工艺相比，能更有效地去除纺丝油和其他添加剂。挤出后，通过缩聚 PET 熔体，在 IV 优化器中再次提高粘度，使其达到相应纤维生产所需的水平。James Qiu 强调说：“通过这种回收工艺，我们可以获得高质量的 rPET 粒子，以 100% 的再生料添加比例，再次生产极其细密的纤维”。

为了推动 PET 纤维再循环领域的发展，EREMA 集团在其位于奥地利安斯费尔登的总部建立了自己的纤维技术中心。在这里，一个跨学科团队以工业规模运营着一个设备齐全、可变速强的回收工厂，并配备了必要的外围技术，也可供客户进行试运行。

通过当地分支机构服务客户

以客户为导向一直是 EREMA 的既定目标。为了更快地应对中国客户需求，公司于 2001 年在上海成立了分公司。“我们当地的工艺工程和调试技术人员可以高效快速地相应客户需求，满足 PET 回收及其目标应用的特定技术要求，”James Qiu 说。EREMA专家还为食品级rPET生产所需的授权申请提供支持。而在亚洲其他许多地区，EREMA 与当地代表合作，并在当地设立销售和服务团队。

The ongoing growth of the PET industry, especially in Asia and Africa, is boosting the demand for recycling solutions for PET waste. “We offer the right systems for specific requirements, including for direct food contact,” says James Qiu, General Manager at EREMA Shanghai. The central element is the tried-and-tested VACUREMA® technology, which the international machine manufacturer launched 25 years ago and has been continuously developing ever since. Over 400 PET systems for food grade are in operation worldwide using various technologies such as VACUREMA® Basic, Advanced, Prime, MPR, and VACUNITE®, notching up a total capacity of more than four million tonnes per year. In the last three years alone, EREMA has delivered 100 systems for the bottle market. Almost 60 percent of these are bottle-to-bottle solutions. The rest are divided between bottle-to-sheet, PET strapping and the bottle-to-fibre segment, which is going from strength to strength.

Decontamination already prior to extrusion

Reliable recycling performance is needed to produce food-safe, visually flawless rPET pellets from starting materials of widely varying quality. The main advantage of VACUREMA® machines

is the SafeFlake technology in the vacuum reactor, which brings together decontamination, drying and IV treatment. Thanks to the pretreatment of the PET flakes in vacuum at the correct temperature, moisture and migration substances are effectively removed already prior to extrusion. This prevents any hydrolytic and oxidative decomposition of the melt in the extruder. The quality of the rPET pellets remains consistently high even if the parameters of the input material – such as moisture, mixture or bulk density – vary.

In addition to the quality aspects, the financial factors are also a strong argument in favour of this recycling process. This is because both the total costs of acquisition and use (total costs of ownership) and the energy consumption are comparatively low. "The specific overall energy consumption of a VACUREMA® Prime system is only 0.295 kWh/kg, for example. This is a top energy efficiency value compared to conventional PET processing lines on the market," says Christoph Wöss, Business Development Manager for the Bottle segment at EREMA. VACUREMA® Prime is a version of the process where two crystallisation dryers immediately upstream from the vacuum reactor operate in batch mode alternately – also in vacuum – to decontaminate the material. The intrinsic viscosity (IV) is increased thanks to Solid State Polycondensation (SSP) on the flake.

Double safety with VACUNITE®

Legal requirements and the much publicised commitment of well-known brand owners are pointing the way towards a big increase in the proportion of recycle used in products such as PET bottles. "Recycling machines have to produce better quality output material despite the decreasing quality of the input material," explains Christoph Wöss. "That is where VACUNITE® comes in, to meet these requirements." Together with Polymetrix, EREMA has developed the tried-and-tested VACUREMA® process to include vacuum-assisted SSP in a nitrogen atmosphere. All of the thermal process steps are performed in nitrogen and/or vacuum.

Decontamination carried out at the beginning and end of the processing sequence means double safety for users. "With VACUNITE® we offer our bottle-to-bottle customers a new technology which sets new standards at all levels from technical performance to recycle quality,"

在 2024 年国际橡塑展上，EREMA 团队将再次与感兴趣的莅临者深入探讨。(图为：2023 年国际橡塑展) (图片版权：EREMA GmbH)

At Chinaplas 2024, the EREMA expert teams will once again be on hand to share their expertise with visitors (Photo from Chinaplas 2023) (Photo credits: EREMA GmbH)

says Christoph Wöss. The nitrogen used in the SSP is purified and can be fed back into the processing stage upstream so that nitrogen consumption is reduced as a result. Another advantage of VACUNITE® is the improved colour values. "We can retain the transparency of the material even after several recycling cycles, which makes bottle-to-bottle recycling fit for the future – for a truly functional circular economy," says Christoph Wöss.

Food-safe rPET on the increase – also in the textile industry

As well as in the food sector, food-compliant rPET is also playing an increasingly important role in the textile industry. Well-known brands are relying more and more on recycled PET as a material that meets the requirements for food grade specifications in order to be able to offer their customers textiles that are both sustainable and safe from a health perspective. This trend is reflected by the increase in sales of bottle-to-fibre applications at EREMA. Asia is an important market in this segment.

Ultimately, the textile industry is increasing the demand for PET recycling. Around two thirds of the total volume of PET flows into the production of synthetic fibres. EREMA has responded by setting up its own business application for fibres and textiles.

Gentle material preparation for fibre-to-fibre

The INTAREMA® FibrePro:IV machine was developed specifically for fibre-to-fibre recycling. Proven INTAREMA® technology combined with the new IV Optimiser succeeds in processing shredded PET fibre materials heavily contaminated by spinning oils in such a way that the finest fibres can be produced again from the recycled pellets. The system features active surface renewal of the melt in a vacuum atmosphere, which focuses on removing the spinning oils and other additives more efficiently than conventional PET recycling processes. Following extrusion, the intrinsic viscosity is increased in the new IV Optimiser by



polycondensation of the PET melt to the level that is needed for fibre production. "With this recycling process, we achieve high-quality rPET pellets that are used for the production of fibres as fine as 2 dtex, even with an rPET content of 100 percent," emphasizes James Qiu.

To drive forward developments in PET fibre recycling, the EREMA Group has set up a fibre technical centre at its headquarters in Ansfelden, Austria. Here, a team of experts from a wide spectrum of disciplines operates a fully equipped and flexible industrial-scale recycling machine. It includes the peripheral technology required and is available to customers for trials.

Local subsidiary focuses on customers

Focusing on customers has always been a clear goal for EREMA. In order to be able to visit customers in person at short notice in China, the company opened a subsidiary in Shanghai in 2001. "Our experts in processing technology and start-up are available to meet our customers' special requirements in PET re-

cycling and beyond," says James Qiu. The EREMA experts also help prepare for the approval procedures required for the production of food contact compliant rPET. In many other regions in Asia, EREMA works together with local representatives and has its own in-country sales and service teams.

EREMA在2024年中国国际橡塑展 : 2.1展馆C55展位

EREMA at Chinaplas 2024: Hall 2.1, Stand: 2.1C55

► **EREMA Group**
Unterfeldstr. 3, 4052 Ansfelden, Austria
www.erima.com

ECON

UNDERWATER PELLETIZING SYSTEMS
水下造粒系统

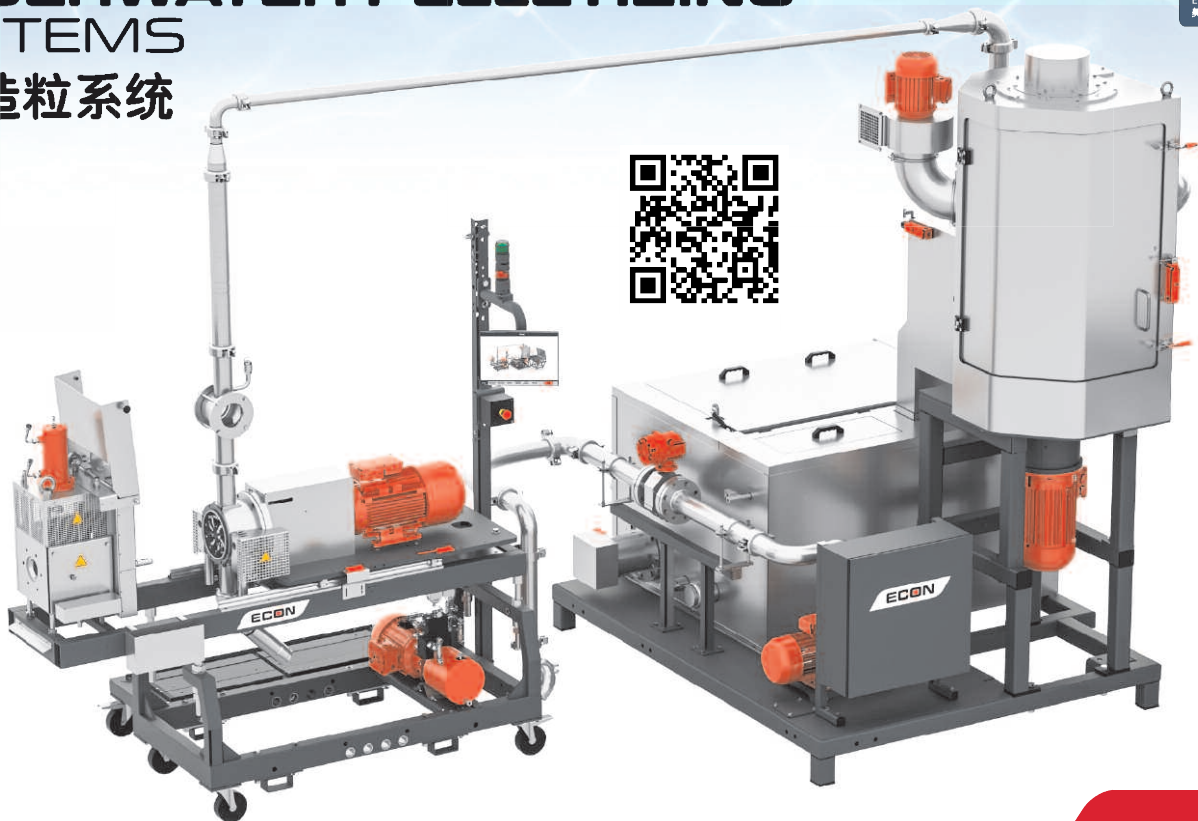

ECON 中国区独家代理:
瀚辰时工业技术(上海)有限公司

在 Chinaplas 2024 呈现创新的展台设计理念与多款亮点产品

With New Booth Concept and Several Product Highlights at Chinaplas 2024

2024 国际橡塑展 (Chinaplas) 将于 4 月 23 - 26 日在上海举办。SIKORA 作为采用创新式测量、控制与分拣技术的设备生产制造商，将在展会上为您带来在管材挤出生产、颗粒原料生产加工中进行质量控制与成本优化的新型设备。来访者不仅可以看到 SIKORA 新款首发产品，还可同时感受我们极具创意的展台设计。

At Chinaplas 2024 from April 23 to 26 in Shanghai, SIKORA, manufacturer of innovative measuring, control and sorting technologies, will be demonstrating its range of current, improved and new products for quality control and cost optimization in hose and tube extrusion and material production and processing. Visitors can look forward to a product premiere and a new booth concept.

新款产品首发

SIKORA 将在 2024 国际橡塑展 (Chinaplas) 上展出一款用于管道挤出生产线上的创新型测量设备。“这款设备的推出代表着我们在技术方面不断的钻研与创新，它重新定义了管材挤出生产线的测量技术领域。该设备搭载了行业领先技术，卓越的仪器性能可以帮助用户提高生产效率、降低生产成本，是一款非常值得您期待的产品。”SIKORA 市场部总监 Katja Giersch 说道。来访者可在 SIKORA 展台体验了解该设备的优势。

CENTERWAVE 6000

用于测量外径为 32 - 1,600 mm 的管道，是实现高效生产率的首选设备。该设备可直接安装在生产线上的第一段真空箱后，开机后即可收到管道的测量数值。设备采用创新的毫米波测量技术，配备连续旋转的收发器，实现对产品的整个圆周进行测量，获得外径与壁厚值。完整且精确的测量数值可确保挤出生产快速调中，自动将壁厚控制在最小值，以实现最佳的材料使用与可持续生产，并节省生产成本。

PURITY SCANNER ADVANCED

SIKORA 还将在展会上展出用于检测并分拣塑料颗粒的洁净度检测分拣系统 PURITY SCANNER ADVANCED。即便是细小的、容易遗漏的杂质也能通过该系统被可靠地检测并分拣出来。由于采用成像系统组合设计理念，该系统可以根据被检测材料的类型选择不同的成像系统。25 μm 高分辨率的光学成像系统可检测黑点与污点，X 射线成像系统可检测小至 50 μm 的金属杂质。市场上常见的设备最多只配备两个光学成像系统，一旦杂质位于成像系统的外部，由于相对较低的覆盖范围，很快就达到了测量能力的上限，容易出现漏检的情况。PURITY SCANNER ADVANCED 通过吹气装置自动剔除

检测到的杂质。为了优化杂质分拣的带出比，SIKORA 研发了“自定义吹除”功能。客户可以提前定义材料中的哪些杂质是相对可接受的，并为这些杂质选择较少的吹气阀，从而降低它们的带出比，例如，材料中经常出现的较小的、浅色黑点。另一方面，该系统可选择打开更多吹气阀用于剔除具有关键影响的杂质——例如，可能损害后续最终产品功能的金属杂质。通过将可靠的检测方式与“自定义吹除”功能相结合，可确保材料的最高洁净度。同时，该系统还可以优化生产过程、降低杂质的带出比，从而节省生产成本，实现可持续生产。

X-RAY 6000 PRO

SIKORA 测厚仪 X-RAY 6000 PRO 采用 X 射线检测技术，可以持续提供挤出生产线上管材的壁厚、偏心、内/外径的测量数据。生产数据可清晰地呈现在数据显示处理系统 ECOCONTROL 6000 显示器上。X-RAY 6000 PRO 可安装于挤出机之后，或两个真空箱/冷却水槽之间，也可安装于生产线末端进行冷端测量。从调试之日起，该系统就可以将壁厚控制在最小值范围内，这为用户节省了大量的材料与成本。



在 Chinaplas 展会，来访者可以了解到 CENTERWAVE 6000 在管道挤出生产线上如何对外径与壁厚进行测量

At Chinaplas customers can look forward to the CENTERWAVE 6000 that measures diameter and wall thickness of tubes and pipes during extrusion

展台的创新设计理念体现了 SIKORA 追求完美的目标

此次展会，SIKORA 在展台设计上也呈现了极具创意的设计，它再次体现了 SIKORA 追求完美的理念。“我们不但希望为客户提供最高质量的产品和最完善的服务解决方案，还希望在专业的讨论与良好的氛围中感受到我们的态度。我们诚挚地邀请前来展会的参观者莅临我们的展台，与我们进行充分的交流。在我们的展台上，相信您会获得良好的体验感。”福州西科拉电子科技有限公司总经理陈万彬先生说道。

Premiere of a new product

At Chinaplas 2024, SIKORA will unveil an innovative measuring device that redefines the segment of measuring technology for hose and tube extrusion lines. "With the new product, we bring movement to measuring technology. Our customers can look forward to a reliable, future-oriented product that continues to lead the way with its performance and make a significant contribution to increasing productivity and cost efficiency in production," says Katja Giersch, Head of Corporate Communications at SIKORA. Visitors can familiarize themselves with the advantages of the system live at the exhibition stand.

CENTERWAVE 6000

For measuring tubes and pipes with a diameter from 32 mm to 1,600 mm, the CENTERWAVE 6000 is the solution for maximum efficiency. Immediately after the first vacuum tank, the system provides all product dimensions. This is achieved by innovative millimeter wave technology with a continuously rotating transceiver that measures the diameter and wall thickness gapless over the entire product circumference. The extensive and precise measuring data enables fast centering of the extrusion tools respectively an automatic control to the minimum wall thickness for optimum material usage and overall sustainability as well as cost saving.

PURITY SCANNER ADVANCED

At Chinaplas SIKORA exhibits the PURITY SCANNER ADVANCED that is used for inspection and sorting of plastic pellets. Even the smallest, critical contamination are reliably detected and sorted out by the system. Thanks to the modular concept, different camera types can be used depending on the inspected material. In addition to optical 25 µm high-resolution cameras, which detect black specks and discolorations, an X-ray camera can be installed to detect metallic contamination down to 50 µm in the pellet. Common systems on the market have a maximum of two optical cameras. However, these quickly reach their limits due to relatively low coverage as soon as the contamination are outside the cameras' field of view. The PURITY SCANNER ADVANCED automatically sorts out detected contamination via a blow-out unit. For optimizing the by-catch, SIKORA has developed a "hybrid blow-out" feature. The customer defines in advance which contaminants in the material are uncritical and select a smaller blow-out unit for these, so that their by-catch is reduced. These include, for example, small, light-colored black specks that frequently occur in the material. On the other hand, a larger blow-out unit is specified for critical contaminants, for example metal contaminants, which can impair the functionality of the subse-

quent end product. Both the reliable detection and hybrid blow-out ensure the highest material quality. At the same time, production processes are optimized and the reduced by-catch contributes to cost-efficient and sustainable production.

X-RAY 6000 PRO

With the X-RAY 6000 PRO, SIKORA presents a system based on X-ray technology that continuously provides measuring data on wall thickness, eccentricity and inner and outer diameter of hoses and tubes in extrusion lines. These are clearly displayed on the monitor of the ECOCONTROL 6000 processor system. The X-RAY 6000 PRO can be used either after the extruder, between two vacuum tanks/cooling sections, or at the end of the line for cold measurement. From the first day of commissioning, the system enables the wall thickness to be reduced to the smallest permissible value. This results in significant material and cost savings for the user.

New booth concept underlines SIKORA's claim to perfection

SIKORA presents itself at the Chinaplas with a new booth concept and thus underlines its claim to perfection. "We do not only want to offer our customers the best product and service solutions, we also want them to experience this attitude in a professional atmosphere. Therefore, we cordially invite our customers to see and discuss our technologies with our experts. On our booth, they should feel good all around," says Wanbin Chen, President of SIKORA China.

SIKORA 参加 2024 年中国国际橡塑展：展位号 2.1F62

SIKORA at Chinaplas 2024: Booth 2.1F62

X-RAY 6000 PRO 在挤出生产线上测量管材的壁厚、偏心以及内/外径

The X-RAY 6000 PRO measures the wall thickness, eccentricity and inner and outer diameter of hoses and tubes in extrusion lines



► SIKORA AG
Bruchweide 2, 28307 Bremen, Germany
www.sikora.net

OMNI回收机的新系列：创新的脱挥和去污技术，适用于现有和新兴的回收应用

New Range of OMNI Recycling Machines – Innovative Devolatilization and Decontamination Technologies for Existing and Emerging Recycling Applications

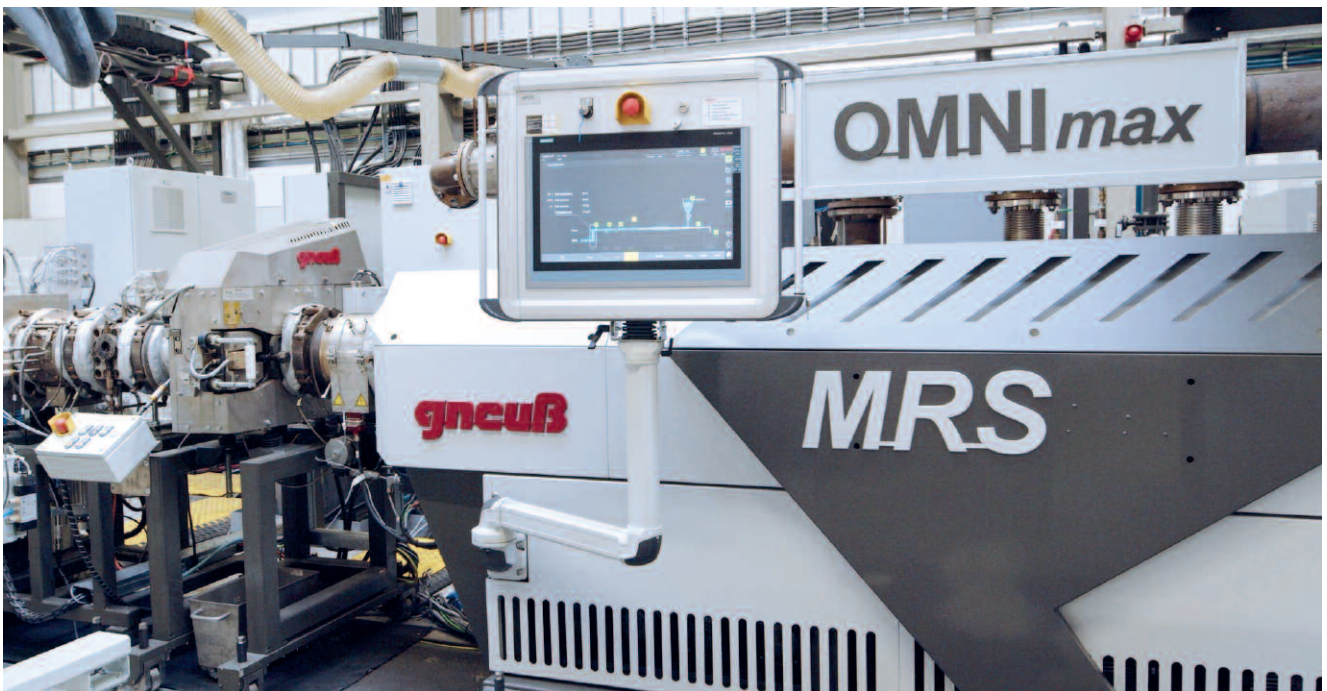

配备 MRS 挤出机和 RSFgenius 过滤系统的格诺斯 OMNImax 回收机

Gneuss OMNImax recycling machine with MRS extruder and RSFgenius filtration system

用于闭环回收的OMNI回收机

众所周知，格诺斯MRS挤出技术是聚酯（PET）、聚苯乙烯（PS）、聚丙烯（PP）或聚乙烯（PE）等受污染材料回收的替代品。结合格诺斯的高效旋转过滤系统、优化的真空技术、在线粘度计VIS和格诺斯测量技术，可以针对特定材料设计可定制的回收线。作为一种选择，可以通过3C旋转喂料机将材料送入挤出机。

来自FDA的多份不反对函（LNO）、EFSA合规性和拉丁美洲的当地批准证实了该技术的去污效率。

OMNI回收机的典型应用包括将PET废料（如瓶子、板材回收料或纤维废料）加工成高质量的最终产品，如热成型板材（适用于食品接触）、短纤维、POY、FDY、BCF或捆扎打包带。此外，PS、PP、PE、PLA等多种原材料都可以回收利用。OMNI系列还用于消费后废物的去污，用于生产直接

接触食品的产品，如HDPE瓶盖、咖啡盖，以及PA、SAN或其他聚合物的异味减少和脱气

除了其紧凑的设计，占用的空间非常小，因此通常可以很容易地集成到现有的场所中，OMNI在灵活性方面得分很高。真空、挤出机、定量、脱气时间和过滤器更换的全自动控制确保了最终产品始终如一的高质量，同时允许操作员使用成本更低的原材料。在当今紧张和波动的材料市场中，无论输入材料的特性如何，能够进行生产变得越来越重要，尤其是在输入材料的质量将发生变化且不确定的未来。

紧凑的设计也带来了非常低的能耗。挤出过程中使用的任何能源都设计为用于下一个工艺步骤。这不仅对电力和天然气消耗有明显影响，而且大大减少了回收过程中的二氧化碳足迹。

多螺杆挤出机 MRS

MRS挤出机基于传统的单螺杆技术，但配备了用于脱挥的多螺杆部分。它可以非常高效和温和地对聚合物熔体进行去污，同时满足直接食品接触标准的要求。此外，MRS挤出机允许使用简单而坚固的真空系统将R-PET直接加工成高质量的最终产品，如包装片材、捆扎带或长丝，而无需预干燥。所有这一切都是通过其独特的专利加工部分实现的。多回转部分是一个包含多个卫星单螺杆的滚筒，由齿圈和小齿轮传动驱动。

卫星单螺杆的旋转方向与主螺钉相反。这不成比例地增加了聚合物熔体的表面交换。一个用于通风的大开口，暴露卫星单螺杆的整个长度，完全处于真空状态。这提供了对聚合物熔体的出色且不受限制的接触，聚合物熔体的表面在多螺杆部分的卫星螺杆的作用下不断以极高的速率更换。可用于脱挥的表面积和表面积交换率远远大于其他挤出系统。由于聚合物熔体上的热应力和机械应力最小化，因此在MRS挤出机上处理的回收具有出色的光学和机械性能。

只需一个简单的挤出步骤，即可彻底去除有害污染物，从而使所得的回收颗粒可以安全地用于食品接触应用。

真空系统

格诺斯开发了自己的真空系统，用于提取挥发性杂质，其中一些具有专利分离系统。由于MRS挤出机的熔体表面较大，因此吸力比传统系统高得多，因此可以从聚合物中提取大量挥发性杂质，并通过自动分离器系统从真空中分离出来。除了水环泵真空系统外，格诺斯还提供带有合适分离器的深真空系统。

展出的真空系统是一种水环泵系统，专为 25-40 mbar 的真空而设计，即使在回收应用中也能提供高度自动化和过程控制，维护成本低。

格诺斯过滤技术

格诺斯的顶级型号 RSFgenius 采用集成的反冲洗系统，可为非常苛刻的应用和最高质量的要求提供自清洁功能。筛网可自动重复使用多达 400 次，过滤细度低于 10 微米/1200 目。

无论是在造粒、片材、纤维还是管道应用中，将全自动 RSFgenius 改装到现有的挤出生产线上，都可以使用污染更严重（通常更便宜）的材料和/或使用更精细的筛网。每次改造都是量身定制的，通常不需要移动任何现有设备。

在线粘度计 VIS

OMNI 回收系统以及任何其他挤出生产线都可以配备创新且紧凑的 VIS 在线粘度测量系统。使用高精度的刚性齿轮泵，一小部分聚合物熔体从主熔体通道分流，并迫使其通过精确制造的开槽毛细管。在那里测量的数据可用于提高质量保证。在 OMNI 回收线上加工 PET 时，粘度计可以精确控制最终产品的粘度。

挤出测量技术

格诺斯为您的压力和温度测量提供灵活的传感器解决方案，可根据您的应用进行个性化定制。磨损、腐蚀、温度，格诺斯为每一个挑战提供正确的解决方案。

格诺斯交付速度快。无论是标准传感器还是特定应用的定制解决方案。灵活的制造结构允许最短的交货时间。

格诺斯创造安全。除了符合标准的压力监测外，格诺斯还为测量设备提供必要的质量保证。

格诺斯是数字化的。最新一代的格诺斯传感器和压力监测器完全以数字方式进行通信。用于数字仪表监控的集成 RFID 芯片适用于所有传感器型号。

获得专利的旋转过滤系统 RSFgenius

Patented Rotary Filtration System RSFgenius

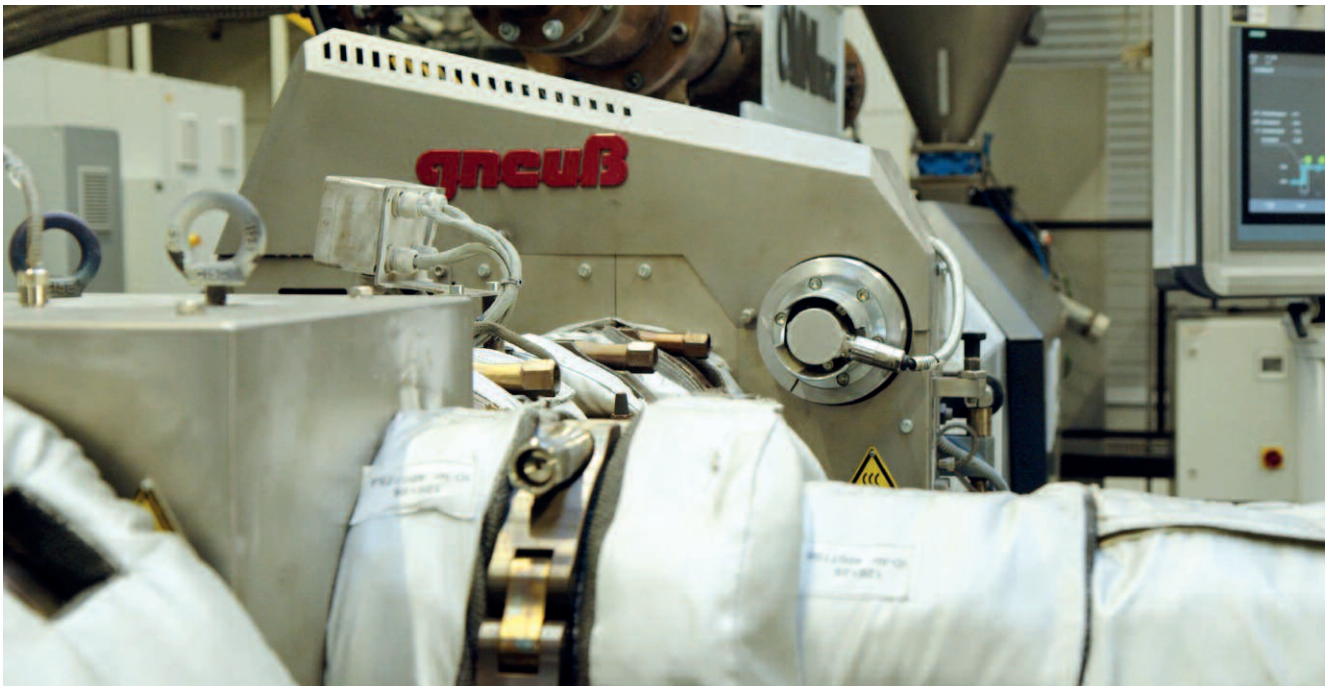

OMNI recycling machines for closed loop recycling

The Gneuss MRS Extrusion Technology is well known as an alternative for the recycling of contaminated materials such as Polyester (PET), Polystyrene (PS), Polypropylene (PP) or Polyethylene (PE). In combination with Gneuss' highly efficient Rotary Filtration Systems, optimised vacuum technology, an Online Viscometer VIS and Gneuss measurement technology, customisable recycling lines can be designed for a specific material. As an option, material can be fed to the extruder via a 3C Rotary Feeder.

Multiple Letters of Non-Objection (LNOs) from the FDA, EFSA compliance and local approvals in Latin America confirm the decontamination efficiency of the technology.

Typical applications for OMNI recycling machines include the processing of PET scrap, such as bottles, sheet regrind or fibre waste, into high quality end products such as thermoformed sheet (suitable for food contact), staple fibre, POY, FDY, BCF or strapping. In addition, a wide range of raw materials such as PS, PP, PE, PLA can be recycled. The OMNI series is also used in the decontamination of post-consumer waste for the production of direct food contact products such as HDPE bottle caps, coffee caps and for odour reduction and degassing of PA, SAN or other polymers.

In addition to its compact design, which takes up very little space and can therefore usually be easily integrated into existing premises, the OMNI scores highly in terms of flexibility. The fully automatic control of vacuum, extruder, dosing, degassing time and filter change ensures a consistently high quality of the end product while allowing the operator to use lower cost raw materials. In today's tight and fluctuating materials market, it is becoming increasingly important to be able to produce regardless of the properties of the input materials, especially in the future when the quality of the input materials will vary and be uncertain.

The compact design also results in very low energy consumption. Any energy used in the extrusion process is designed to be used in the next process step. This not only has a noticeable effect on electricity and gas consumption, but also significantly reduces the CO₂ footprint of the recycling process.

Multiple screw extruder MRS

The MRS extruder is based on conventional single screw technology but is equipped with a multiple screw section for devolatilization. It enables very efficient and gentle decontamination of the polymer melt,

whilst achieving the requirements for direct food contact standards. In addition, the MRS extruder permits the processing of R-PET directly into high quality end products such as packaging sheet, strapping tape or filaments without pre-drying by using a simple and rugged vacuum system. All this is achieved by means of its unique and patented processing section. The Multi Rotation Section is a drum containing multiple satellite single screws, driven by a ring gear and pinion transmission.

The satellite screws rotate in the opposite direction to the main screw. This disproportionately increases the surface exchange of the polymer melt. A large opening for venting, exposing the full length of the satellite screws, is completely under vacuum. This provides excellent and unrestricted access to the polymer melt, the surface of which is constantly replaced at an extremely high rate by the action of the satellite screws in the multiple screw section. The surface area – and the surface area exchange rate – available for devolatilization are far greater than in other extrusion systems. As the thermal and mechanical stress on the polymer melt is minimized, reclaim processed on the MRS extruder has excellent optical and mechanical properties.

In a single, simple extrusion step, harmful contaminants can be removed so thoroughly that the resulting recycled pellets are safe for use in food contact applications.

Vacuum system

Gneuss has developed its own vacuum systems for the extraction of volatile impurities, some of which have patented separation systems. Due to the large melt surface in the MRS extruder, the suction capacity is considerably higher than in conventional systems, so that large quantities of volatile impurities can be extracted from the polymer and separated from the vacuum flow by means of automated separator systems. In addition to



格诺斯测量技术产品

Gneuss measurement technologies
products

a water ring pump vacuum system, Gneuss also offers deep vacuum systems with appropriate separators.

The vacuum system on display is a water ring pump system designed for vacuums of 25 to 40 mbar and offers high automation and process control with low maintenance, even in recycling applications.

Gneuss Filtration Technology

Gneuss’ top model, the RSFgenius, operates with an integrated back-flushing system offering self-cleaning for very demanding applications and highest quality requirements. Screens can be automatically re-used up to 400 times and filtration finenesses below 10 microns/1200 mesh are available. There will be an RSFgenius 150 on display, with an active screen area of 450 cm²/70 square inches, for 1000 kg/h (2.200 lbs) of R-PET with a filtration fineness of 75 microns (200 mesh).

Retrofitting a fully-automatic RSFgenius to an existing extrusion line, whether in a pelletizing, sheet, fiber or pipe application, permits the use of more contaminated (and often cheaper) material and/or the use of finer screens. Every retrofit is tailor-made and usually without the need to move any existing equipment.

Online viscometer VIS

OMNI recycling systems as well as any other extrusion line can be equipped with the innovative and compact VIS online viscosity measurement system. Using a high-precision, rigid gear pump, a small partial flow of polymer melt is diverted from the main melt channel and forced through a precisely manufactur-

ed slotted capillary. The data measured there can be used to improve quality assurance. When processing PET on an OMNI recycling line the viscometer allows precise control of the end product viscosity.

Gneuss Measurement Technology

Gneuss provides flexible sensor solutions for pressure and temperature measurements, individually tailored to your application. Abrasion, corrosion, temperature, Gneuss offers the right solution for every challenge.

Gneuss delivers fast – whether standard sensor or application-specific customized solution. The flexible manufacturing structure allows shortest delivery times.

In addition to standard-compliant pressure monitoring, Gneuss offers the necessary quality assurance of the measuring equipment.

The latest generation of Gneuss sensors and pressure monitors communicates completely digitally. Integrated RFID chips for digital gauge monitoring are available for all sensor models.

格诺斯在2024年中国国际橡塑展 :
2.1展馆H26展位

Gneuss at Chinaplas 2024: Booth H26, Hall 2.1

► **Gneuss Kunststofftechnik GmbH**
Moenichhusen 42, 32549 Bad Oeynhausen, Germany
www.gneuss.com

SMART EXTRUSION

A SPECIALIZED WEB PORTAL

- ▶ News about relevant products and events
- ▶ Detailed reviews of various smart technologies
- ▶ Case studies from processors
- ▶ English, German and Chinese

- ▶ Video clips demonstrating smart equipment in live action
- ▶ Latest magazines available for reading and downloading
- ▶ Weekly e-mail newsletters

www.smart-extrusion.com

特种、功能性和可持续性薄膜的解决方案

Solutions for Special, Functional and Sustainable Films



高效薄膜拉伸生产线 / *Highly efficient film stretching line*

展会亮点：适用于各种高科技应用的特种薄膜生产线。

Show highlight: Specialty film lines for a wide variety of high-tech applications

在上海举行的 2024 年中国国际橡塑展（2.1 号展馆，H62 号展位）上，布鲁克纳公司将重点放在全球需求量巨大的特种薄膜制造上，特别是在快速增长的电动汽车和新能源领域：

- 电池隔膜：生产线概念和定制的机器组件，确保高效、低生产成本和一致的薄膜质量，已在全球领先的制造商中得到验证
- 复合集流体膜：降低厚度、减轻重量、减少金属含量、以及提高安全性和每个电池具有卓越的能量密度 – 布鲁克纳展示了最新的拉伸技术
- 电容膜：分次和同步拉伸工艺，可制造用于电动汽车应用

的极薄高温薄膜或用于电力行业上可再生能源应用的高能量密度薄膜

- 太阳能背板：首次展示：一条高效的6.8米宽生产线，每小时可生产出6吨厚度达250微米的BOPET厚膜，服务于光伏应用增长市场
- 获得专利的LISIM 线性电机同步拉伸工艺的最新发展，非常适合各种特殊薄膜的高效生产

除了为快速增长的技术型薄膜行业提供解决方案外，布鲁克纳机械还将展示在包装薄膜制造中提高（能源）效率和可持续性以及循环性的进一步发展：

- 高效、快速的高产量生产线，以达到 BOPP、BOPET、BOPA 薄膜生产的低单位能耗
- 智能拉伸烘箱管理，以达到更节能效果
- 通过特殊的直接回收系统和增加收卷机上A级薄膜的比例，减少原材料的使用，实现薄膜生产中的“零浪费”
- 生物基和生物可降解双向拉伸包装薄膜的解决方案，例如由 PLA/PHA 制成的薄膜
- 单一材料解决方案可闭合 BOPP、BOPET 和 BOPE 塑料包装的生命周期，包括独特的 BOPE/BOPP 兼容生产线，使薄膜制造商能够对市场趋势做出快速、灵活的反应

布鲁克纳机械有限公司在2024年中国国际橡塑展上亮相：2.1展馆 H62展位

At Chinaplas 2024 in Shanghai (*Hall 2.1, Booth H62*) Brückner's clear focus is on the manufacturing of specialty films which are in great demand worldwide, especially for the rapidly growing e-mobility and new energy sector:

- **Battery separator films:** Line concepts as well as customized machine components guaranteeing high energy efficiency, low production costs and consistent film quality – proven at leading manufacturers around the globe
- **Composite current collector films:** Downgauging, weight saving, reduction of metal as well as increased safety and an outstanding energy density per cell – Brückner presents latest stretching technologies

- **Capacitor films:** Sequential as well as simultaneous stretching process to manufacture extremely thin and high-temperature films for EV applications or high energy density film for renewable energy applications in the power industry
- **Solar back sheet:** For the first time presented: a highly efficient 6.8 m wide line with an output of 6 tons/hour of BOPET thick film up to 250µm to serve the photovoltaic applications growth market
- **Latest developments in the patented simultaneous LISIM stretching process,** ideally suited for the very efficient production of a wide variety of specialty films

In addition to the solutions for the rapidly growing technical film sector, Brückner Maschinenbau will also present further developments for increased (energy) efficiency and sustainability as well as circularity in packaging film manufacturing:

- Efficient and fast high output lines for a low specific energy consumption in BOPP, BOPET, BOPA film production
- Intelligent stretching oven management for even more energy saving
- Decreasing use of raw materials and "zero waste" in film production with a special direct recycling system and an increased proportion of A-grade film on the winder
- Solutions for bio-based and bio-degradable biaxially stretched packaging films, e.g. made of PLA/PHA
- Mono-material solutions to close the life cycle of BOPP, BOPET and BOPE plastic packaging, including unique BOPE/BOPP hybrid lines allowing film manufacturers to react swiftly and flexibly to market trends

**Brückner Maschinenbau at Chinaplas 2024:
Hall 2.1, Booth H62**



➔ **Brückner Maschinenbau
GmbH & Co. KG**
Königsberger Str. 5-7,
83313 Siegsdorf, Germany
www.brueckner.com

顺序电容器薄膜线

Sequential capacitor film line

扎根中国，服务中国： 现有生产线的本土服务解决方案

Local Service Solutions for Existing Film Stretching Lines in China for China

中国认证的夹子和链条车间

*Certified clip and chain workshop
in China*

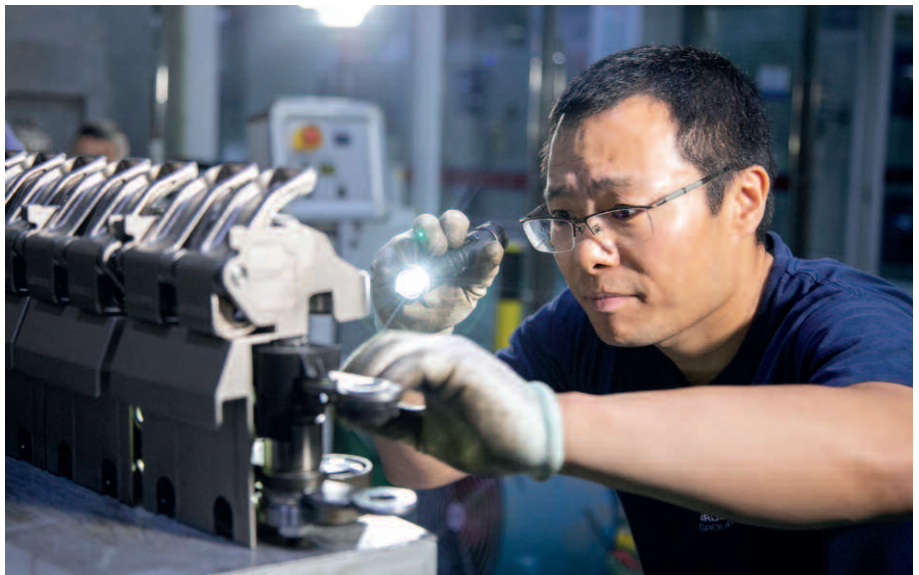

在上海举办的2024中国橡塑展H62展位上，布鲁克纳技术服务公司将展示全新的本土服务解决方案，如产线检查，增加备件库存，还有通过认证的链条与链铰翻新服务，以提高现有薄膜拉伸生产线的利用率，遵循“扎根中国，服务中国”的方针。还将展示必万数字化服务平台更多新的功能和模块，意在增强设备维护效果，简化操作流程，进一步提高生产线利用率。

布鲁克纳技术服务公司携手布鲁克纳机械（中国）有限公司共同为中国客户提供综合服务与数字化解决方案。

链条与链铰车间配备全套FOK5.5.8与FOK8.8系统翻新设备工具

布鲁克纳机械（中国）有限公司链条与链铰车间的最新发展介绍：

最新类型的轴承链条与滑块链条系统FOK5.5.8与FOK8.8已经在苏州成功通过了高质量翻新认证。这一发展标志着我们向前迈进了重要一步，从而使我们的中国客户受益于先进，迅速和高效的服务。现在，苏州车间几乎可以提供所有类型的链条与链铰的翻新服务。

At Chinaplas 2024 in Shanghai, Brückner Servtec presents brand new local service solutions such as audits, enhanced spare parts stocks and certified clip and chain refurbishment to increase the availability of existing film stretching lines according to the motto “in China for China”. Further new features and modules of the Brückner ONE digital service platform are shown which boost and simplify equipment maintenance for higher availability.

在此次中国橡塑展上，布鲁克纳将呈现针对不同类型的滑块与轴承链条的对应检修与翻新解决方案，包括来自其他厂家的双拉生产线的链条。

在翻新车间里，布鲁克纳的专业技术与最先进的高端工具相结合，能够提供多种附加选择，例如：

- 链条与链铰快速翻新
- 检修期间进行链轨检查
- 免费的零件检查
- 现货轴承链条轨道

最大限度减少停机时间，保障薄膜生产线的长期可用性。

苏州备件库存不断增加

布鲁克纳技术服务公司在中国建立了一个全新的备件仓库，以缩短交付周期。该仓库包含各种双拉生产线的所需零件与精选备件，从而确保备件的最快供应。

中国本地检查与服务团队

布鲁克纳机械（中国）有限公司将在2024年加强本地服务能力，将人力增加一倍，扩大服务覆盖范围。专家们将在现场提供故障排除，升级与产线搬迁等多方面的帮助。

网络版必万解决方案的新功能

布鲁克纳技术服务公司将在中国橡塑展商首次推出全新的创新型的必万模块：电子学习与帮助中心，不仅为当前所有必万模块提供多语言，分步说明，还提供薄膜拉伸线技术组件与操作任务的自学视频，使必万用户能够独立解决技术难题。此外，布鲁克纳机械公司的维护，生产，分析模块也将开启预览。

Brückner Servtec with Brückner Group China offers comprehensive services for customers in China and provides support with digitalization solutions:

Complete Clip & Chain Workshop portfolio with FOK 5.5.8 and FOK 8.8 systems

Introducing the latest achievements in Brückner Group China Clip & Chain Workshop: With FOK 5.5.8 and FOK 8.8, the newest types of roller and sliding chain systems have successfully onboarded in certified high-quality refurbishment in Suzhou. This development marks a significant step forward, hence the customers in China benefit from sophisticated, prompt, and ef-

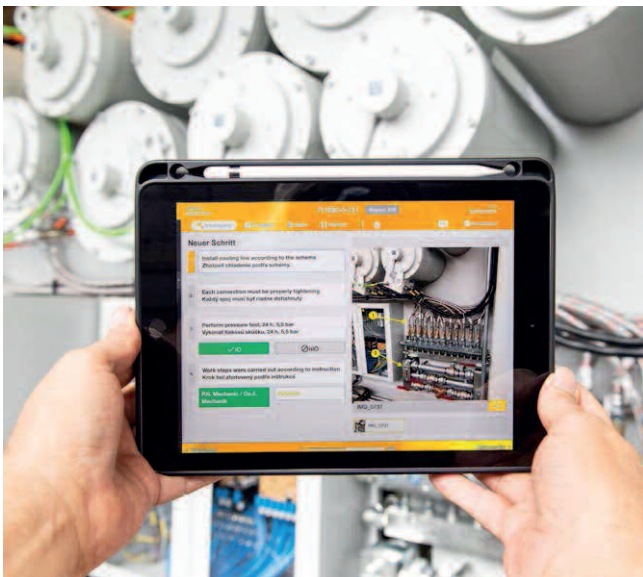

ficient services. The Suzhou based local workshop now offers refurbishment of almost all clip and chain types. At Chinaplas, Brückner presents appropriate overhaul and refurbishment solutions for all different types of sliding and roller chains, including chains for other biax production lines.

Brückner's expertise combined with state-of-the-art high-end tooling and a variety of additional options at the workshop, such as

- fast track clip and chain refurbishment
- chain track inspection during the overhaul period
- free parts inspection or
- roller chain monorails on stock

minimize downtime and ensure long-lasting availability of the film production.

Growing spare parts stock in Suzhou

Brückner Servtec introduces a completely new spare parts warehouse in China to reduce lead time. The warehouse contains selected parts and components of all types of biaxial oriented (BO) lines, thus ensuring the fastest possible availability of spare parts.

Local audit and service team for China

Brückner Group China will strengthen its local service competence in 2024 by doubling the manpower for a higher service coverage. The experts provide on-site assistance with various aspects, such as troubleshooting, upgrades, and line relocations.

New features for web-based Brückner ONE solution

Debating at Chinaplas, Brückner Servtec will introduce the brand-new and innovative Brückner ONE modules e-learning and helpcenter, which not only offer multi-language step-by-step instructions for all current Brückner ONE modules, but also provide self-learning videos on technical components and tasks of the film stretching line, enabling Brückner ONE users to independently resolve technical challenges. Additionally, Brückner Maschinenbau's maintenance, production, and analytics modules will be available for preview.

布鲁克纳服务技术公司参加 2024 年中国国际橡塑展：2.1展馆H62展位

Brückner Servtec at Chinaplas 2024:
Hall 2.1, Booth H62

► **Brückner Servtec GmbH**
Königsberger Str. 5-7, 83313 Siegsdorf, Germany
www.brueckner-servtec.com

必万数字服务平台

Brückner ONE digital service platform

Chinaplas 2024上重点展示本地产品

Local Production Highlighted at Chinaplas 2024

聚合物工程专家MAAG集团将在Chinaplas 2024上展示多种本地化解决方案和国产设备，涵盖造粒设备、回收系统、齿轮泵和聚合物过滤器等产品。展品包括 C-USG 水下拉条切粒机、ERF 350 回收过滤器和BAOLI-3新型干式拉条切粒机。

Polymer engineering specialist MAAG Group is using Chinaplas 2024 to highlight localized and Chinese-manufactured equipment within its wide range of solutions for pelletizing, recycling, pumping and filtering polymers. Products on show include the C-USG underwater strand pelletizer, the ERF 350 recycling filter and the new BAOLI-3 Chinese-made strand pelletizer.

MAAG 集团生产的 BAOLI-3 国产钢绞线切粒机

BAOLI-3 Chinese-made strand pelletizer from MAAG Group



“我们为能够为客户提供越来越多本地化产品感到自豪，” MAAG中国总经理孔凡亮表示，“例如，C-USG是久经验证的德国产M-USG水下拉条切粒机的中国本地化变体。”

“对于C-USG，销售团队将与德国格斯海姆工程和建造部门合作，持续优化本地生产流程，”孔先生继续说道，“模头和切割头等关键部件将由德国提供，而MAAG中国将负责导流槽、粒子干燥机和控制器等单个部件的采购和组装。”

“新C-USG将卓越的品质与有竞争力的价格结合起来，将助力我们在竞争激烈的中国市场上站稳脚跟。”

C-USG 水下拉条切粒机是成熟的 M-USG 设备的本地化版本，M-USG 已在全球范围内成功运行了数十年。C-USG 的造粒质量始终保持出色，造粒速度高达 16,000 公斤/小时，可靠性高。由于采用了高度耐磨的切刀和可快速更换的切割头，该设备具有使用寿命长和可用性高的特点；操作方便，自动化程度高；易于维护。

在回收设备方面，MAAG提供连续式熔体过滤器，包括集团成员Ettlinger公司旗下的 ERF 350回收过滤器，其处理能力可达 3,800 公斤/小时，杂质比例最大为16%（按重量

计）。熔体通过滤筒上的锥形孔从外部流向内部，将纸张、木材、橡胶和金属等污染物留在滤筒外侧，并不断被刮掉。ERF 共有四种型号，处理能力从 1,100 公斤/小时到 10,000 公斤/小时不等。而Ettlinger ECO 系列中与之相对应的四种型号则主要适用于 PET领域，用于处理工厂废料等污染程度较低的物料。

新型 BAOLI-3 是用于混炼和回收的干式拉条切粒机。该设备在中国制造，核心切割组件使用进口零件。根据应用和聚合物类型的不同，共有三种可选型号，产量范围在 20-3,450 公斤/小时之间。该设备的特点包括颗粒质量高、使用寿命长、噪音低、易于在本地和工厂 IT 系统中使用，以及安装灵活，可适应不同的生产环境。

Chinaplas参展观众感兴趣的其他MAAG产品包括：

- extrex6齿轮泵，可比标准齿轮泵处理杂质含量更高的熔体。此外，它还具备吞吐量更高、磨损更少和使用寿命更长等优点。

- PEARLO水下磨面切粒机，用于生产球形粒子，产量可达42,000 公斤/小时。
- CSC 058 换网器，一款坚固耐用的熔体过滤器，适用于热熔胶等应用，配有extrex6齿轮泵和 maax PFC 控制系统。
- MAAG AMN混合耐酸 (HAT) 模板，可抵御酸性侵蚀，减少酸性物质对聚合物切粒机的损害。

“We are proud to be serving our customers with more and more localized products,” said Kong Fanliang, General Manager of MAAG China. “For instance, the C-USG is a local Chinese variant of the well-proven M-USG underwater strand pelletizing system.”

“For the C-USG, individual projects will continue to be planned by the sales team in cooperation with the engineering and construction departments in Grossostheim, Germany,” Mr. Kong continues. “Key parts such as die and cutting heads will be supplied from Germany, but MAAG China will handle procurement and assembly of the individual components such as strand guide sections, pellet dryers and controls.”

“With the new C-USG we will be able to assert ourselves in the hard-fought Chinese market, combining good quality with competitive prices.”

The C-USG underwater strand pelletizing system is a localized version of the proven M-USG, which for decades has operated successfully around the world. The C-USG delivers consistently outstanding pellet quality at up to 16,000 kg/h with high reliability. It features long service life and high availability thanks to the extremely wear-resistant cutting tools and quick-change cutter head; user-friendly operation, with a high level of automation; and easy accessibility for maintenance.

For recycling, MAAG offers continuous melt filters including the ERF 350 from group member Ettliger, which can process up to 3,800 kg/h at contamination levels up to 16% by weight. Melt

flows from the outside to the inside of a continuously rotating drum bearing a large number of conical holes. Contaminants such as paper, wood, rubber and metals remain on the outside of the drum and are scraped off continuously. A total of four ERF models cover throughputs from 1,100 to 10,000 kg/h, while four corresponding models in Ettliger's ECO series dedicated for PET applications target lower contamination levels such as factory waste.

The new BAOLI-3 is a dry-cut strand pelletizer for compounding and recycling. It is built in China using imported components for the core cutting duty. Three models cover throughputs in the range of 20 to 3,450 kg/h, depending on the application and polymer type. Features include high pellet quality, long service life, low noise, ease of use both locally and in terms of factory IT systems, and flexible installation options to suit different production environments.

Other MAAG products of interest to Chinaplas visitors include:

- * extrex6 gear pump for recycling applications can handle a higher percentage of contamination than the standard gear pump. In addition it offers higher throughput, less wear, and longer service life.
- * PEARLO underwater pelletizers producing spherical pellets at up to 42,000 kg/h.
- * The CSC 058 screen changer, a robust melt filter for applications such as hot melt adhesives, supplied with an extrex6 gear pump and maax PFC control system.
- * The Hybrid Acid Resistant (HAT) die plate from MAAG AMN, combines standard stainless steel for strength with Inconel and high-performance tungsten carbide for long-lasting corrosion resistance.

► **Maag Pump Systems AG**
Aspstrasse 12, 8154 Oberglatt, Switzerland
www.maag.com

www.smart-extrusion.com

塑料配混和回收的技术先锋

Pioneering Technologies for Plastics Compounding and Recycling

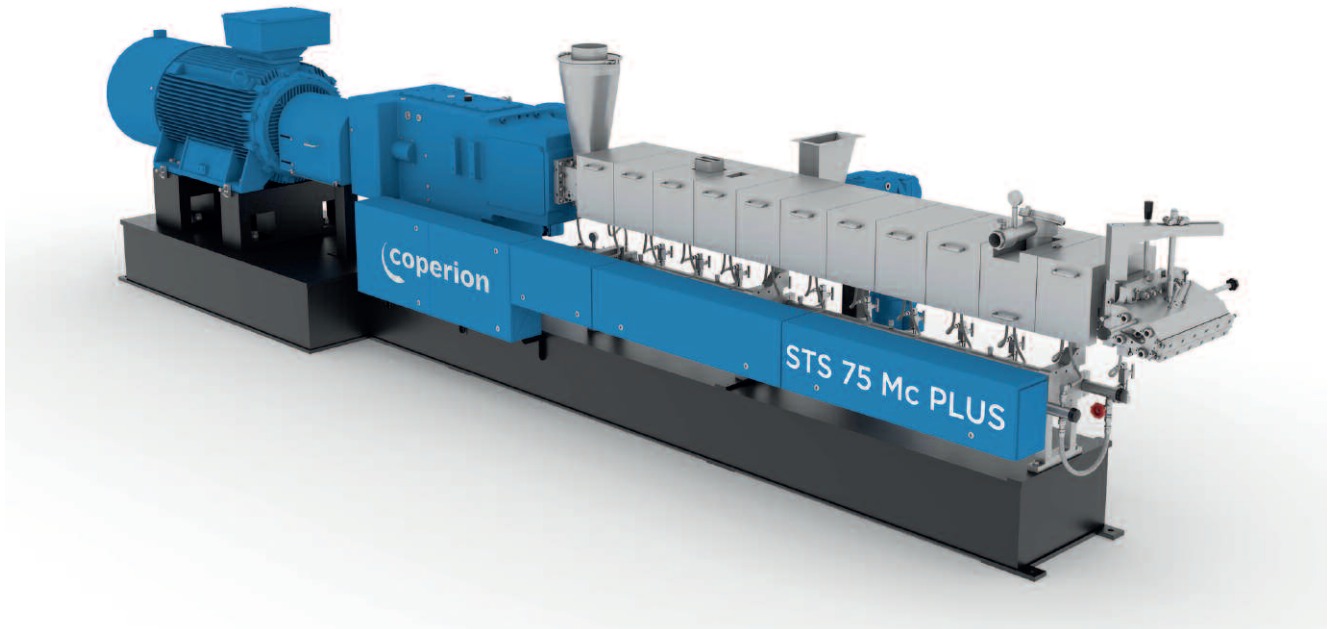

科倍隆全新STS 75 Mc PLUS双螺杆挤出机比扭矩提升至 13.6 Nm/cm^3 ，产能提高20%的同时也提升了产品质量。
(图片：科倍隆德国，斯图加特)

The new Coperion STS 75 Mc PLUS twin screw extruder achieves up to 20% greater throughput with improved product quality, at an increased specific torque of 13.6 Nm/cm^3 (Photo: Coperion, Stuttgart Germany)

在今年的中国国际橡塑展 Chinaplas 上（2024年4月23-26日 | 中国，上海），科倍隆将在2.1号馆F106展位展示其在塑料加工方面的关键技术。本次展出的核心是STS 75 Mc PLUS双螺杆挤出机，其 13.6 Nm/cm^3 的比扭矩提升了STS挤出机20%的产能，并且产品质量也显著提高。

At this year's Chinaplas (23-26 April 2024, Shanghai, PR China) Coperion will present key technologies for processing plastics at Booth F 106 in Hall 2.1. The centerpiece of the exhibits will be the STS 75 Mc PLUS twin screw extruder with its increased specific torque of 13.6 Nm/cm^3 which allows the STS extruder to achieve up to 20% more throughput with markedly higher product quality.

同时，科倍隆和Herbold Meckesheim为制造商提供丰富的专业技术知识和塑料回收的工艺解决方案。自合并以来，两家公司一直不断在开发和优化他们的技术，使整套系统以非常高的效率运行。在这次的国际橡塑展上，科倍隆和Herbold Meckesheim将展示一套虚拟PET回收系统。参观者

可以看到回收系统的内部核心部件，并亲眼看到每个加工步骤的工艺技术细节和高效的部件。

本次展会展出的还有科倍隆ZSK 26 Mc¹⁸双螺杆挤出机搭配一台科倍隆楷创的K-ML-SFS-KT20双螺杆喂料机，一台科倍隆楷创T35-QC快拆式喂料机搭配一台用于补料的2415真

空上料机，以及一台卡尔麦系统的C/S-LW-NT28双螺杆喂料机和STS 75 McPLUS挤出机一起展出。另外，科倍隆楷创还将向中国市场推出ProRate PLUS系列失重式单螺杆和双螺杆喂料机，此次将展出一台带补料功能的PLUS-S喂料机。除此之外，一台用于粒料的CVH550高压阀也将一同展出。

STS 75 Mc PLUS: 改进配混质量，提高产能

针对这款STS 75，科倍隆将STS双螺杆挤出机的比扭矩从11.3 Nm/cm³提升到了13.6 Nm/cm³。配混制造商因此可获得更高的产品质量，并且同时每种应用都能提高20%的产能。要达到这种性能水平以及工艺技术改进的关键是优化驱动段的核心部件。这款新STS 75 Mc PLUS挤出机配备了一款更高功率的电机和根据其高扭矩专门设计的传动箱。芯轴采用高性能材料确保了从传动箱到加工段充分的扭矩输出。

加工段的高填充水平对STS 75 Mc PLUS实现优异的配混质量至关重要。它能同时减少剪切应力和降低熔融温度并且提高了混合性能。其结果是实现高产量的同时有着非常柔和的物料处理。STS 75 Mc PLUS加工段配备的加热棒可以在任何需要的部位高效地加热。

STS挤出机具备基本标准化的优势，结合科倍隆的技术专业知识，从而使设备结构更具成本效益。在STS 75 Mc PLUS的开发过程中，科倍隆从其高端产品ZSK Mc¹⁸中获得了全面的经验。这款新的STS 75 Mc PLUS的产能提高了20%，使其成为一种特别经济的解决方案。每公斤材料成本的下降，投资回报更快。科倍隆保持螺杆内外径比（Do:Di = 1.55）不变，确保工艺可精准放大到STS系列的其他尺寸机型。

由单一供应商提供全套塑料回收系统

科倍隆和Herbold Meckesheim共同实现了一个各种塑料回收应用的工厂，他们在可靠性和高产品质量方面表现出色。从机械加工——塑料的粉碎、洗涤、分离、干燥和团粒——到散装物料处理、喂料和挤出，再到配混和造粒，涵盖了回收塑料的整个工艺链。

同时，科倍隆和Herbold Meckesheim为工业后和消费后废料的机械回收、化学回收、溶剂回收和除臭提供了解决方案，并根据回收的塑料类型量身定制。

灵活多样的科倍隆楷创喂料机

在今年的国际橡塑展上，科倍隆还将通过科倍隆楷创高精度K2-ML-D5-T35快拆式喂料机，装有智能物料振动流化器ActiFlow™和压力补偿系统（ECP）来展示其在所有喂料任务中的专业技能。该喂料机还配备了一台用于补料的2415真空上料机。T35/S60快拆式喂料机（QC）专为快速更换物料和方便清洗的需求而设计。快拆式喂料机（QC）可以快速移除整个带有螺杆的喂料模块，并快速安装上另一套合适的螺杆喂料模块。这种快拆式设计对双螺杆和单螺杆喂料模块都适用。

ActiFlow™智能物料振动流化器是一款革命性的设计，对于流动性差尤其黏性物料，无需在不锈钢料斗内使用搅拌机，可有效避免架桥和老鼠洞的形成。该智能流化器通过对料斗壁施加轻微振动，从而以理想的振幅和频率小心地为料斗内的物料提供流化动力，由控制器根据物料流自动调节。它专为科倍隆楷创失重式喂料机设计。

2400系列真空上料机可为大产量，远距离输送物料到一个或多个目的地的时，提供大容量的测序系统。他们是为散装物料处理行业气力输送粉料、颗粒料而设计的高品质产品，其输送率范围从327到6,804 kg/h（720到15,000 lb/h）。此次展出的是2415粒料上料机。

此外，科倍隆还将展示一台预配置尺寸S的ProRate PLUS单螺杆喂料机，搭配用于补料的2410上料机。这种连续称重的喂料机非常坚固，并因其高性价比脱颖而出。ProRate PLUS生产线被设计成一种特别经济的解决方案，用于流动物料的可靠喂料。科倍隆通过PLUS-MT双螺杆喂料机扩展了ProRate PLUS喂料机产线，尤其适用于粉料的喂料。

来自科倍隆和Herbold Meckesheim的塑料回收设备具备非常出色的可靠性，回收产品的质量非常高。
(图片：科倍隆德国，斯图加特)

The reliability of plastics recycling machinery from Coperion and Herbold Meckesheim excels, achieving very high recycle product quality (Photo: Coperion, Stuttgart Germany)

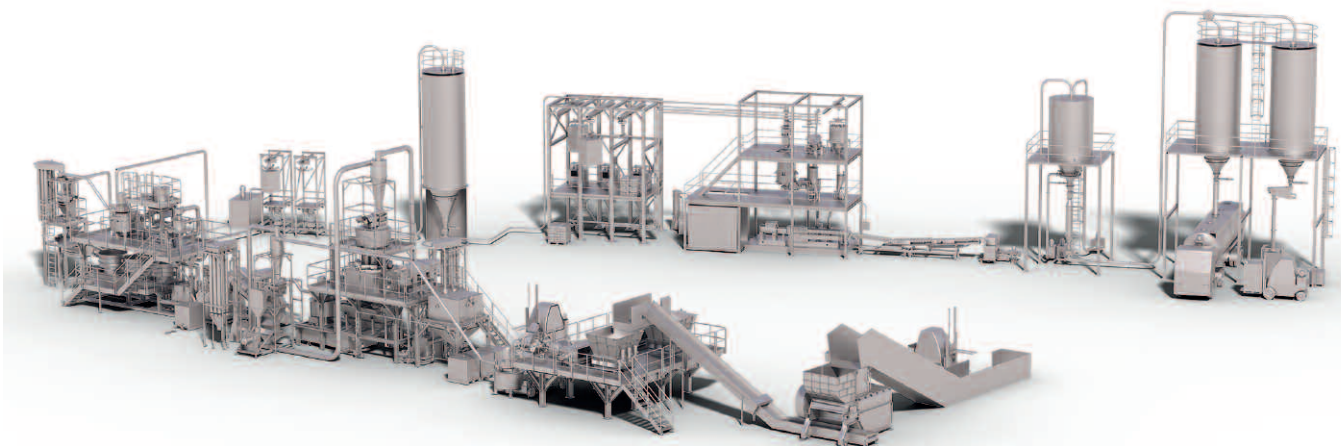

Together, Coperion and Herbold Meckesheim offer operators broad expertise in technology and process solutions for plastics recycling. Since their merger, both companies have continued to develop and optimally attune their technologies so that entire systems excel in operation with extremely high efficiency. At Chinaplas, Coperion and Herbold Meckesheim will display a virtual PET recycling installation. Visitors to the booth can peer inside key components of the recycling installation and see for themselves the process-technical details in each process step and the high efficiency of each component.

Other exhibits at Booth F106 in Hall 2.1 include the Coperion ZSK 26 Mc¹⁸ twin screw extruder with a K-ML-SFS-KT20 twin screw feeder from Coperion K-Tron, a Coperion K-Tron T35-QC quick change feeder shown with a 2415 vacuum receiver for refilling ingredients, and a C/S-LW-NT28 twin screw feeder from Colormax system will be shown with STS 75 McPLUS extruder. In addition, Coperion K-Tron will be introducing the Pro-Rate PLUS line of gravimetric single and twin screw feeders to the Chinese market, showing a PLUS-S feeder with refill. A CVH 550 high pressure rotary valve for granulates will also be on display.



STS 75 Mc PLUS: Higher Throughput with Improved Compound Quality

For the STS 75, Coperion has raised the specific torque of the STS twin screw extruder from 11.3 Nm/cm³ to 13.6 Nm/cm³. The compounder thus achieves improved product quality and at the same time up to 20% higher throughput in every application. Critical to this level of performance, along with process-technical modifications, is optimization of the drive's key components. The new STS 75 Mc PLUS extruder is equipped with a high-power motor and a gearbox designed specifically for the high torque. Proven high-performance materials for the screw shafts ensure full torque transmission from the gearbox to the screw elements.

The higher fill level in the process section is crucial to the improved compound quality that the STS 75 Mc PLUS achieves. It reduces both shear stress and melt temperature and improves mixing behavior. The result is an extremely gentle product handling at high throughputs. The process section of the STS 75 Mc PLUS is equipped with heating cartridges that generate heat very energy-efficiently exactly where it is needed.

STS extruders combine the advantages of substantially standardized and thus more cost-effective machine construction incorporating Coperion's technical expertise. In the continued development of the STS 75 Mc PLUS, Coperion has profited from the comprehensive experience gleaned from its high-end ZSK Mc¹⁸ extruders. The new STS 75 Mc PLUS's throughput increase of up to 20% makes it a particularly economical solution. Material costs per kilo drop and return on investment is reached much more quickly. Coperion retained the proven Do:Di = 1.55 ratio of outer to inner screw diameter unchanged, thus ensuring secure scale-up to other STS model sizes.

Complete Plastics Recycling Plants from a Single Source

Coperion and Herbold Meckesheim realize plants for a wide variety of plastics recycling applications, excelling in their reliability and the high product quality they achieve. From mechanical processing – shredding, washing, separating, drying and agglomerating of plastics – to bulk material handling as well as feeding and extrusion all the way to compounding and pelletizing, such plants cover the entire plastics recycling process chain.

Together, Coperion and Herbold Meckesheim offer solutions for mechanical recycling of post-industrial and post-consumer waste, chemical recycling, solvent-based recycling, and deodorization, tailored to the type of plastic being recycled.

科倍隆楷创在其K2-ML-D5-T35失重式喂料机上引入了可靠的、高精度的喂料解决方案。
(图片：科倍隆楷创，瑞士)

*Coperion K-Tron introduces a reliable, high-accuracy feeding solution in its K2-ML-D5-T35 gravimetric feeder
(Photo: Coperion K-Tron, Switzerland)*

Coperion K-Tron Feeders for Maximum Flexibility

Coperion will demonstrate its expertise in all feeding tasks at this year's Chinaplas with its high-accuracy Coperion K-Tron K2-ML-D5-T35 Quick Change feeder equipped with ActiFlow™ smart bulk solid activator and EPC (Electronic Pressure Compensation). The feeder is equipped with a 2415 vacuum receiver for refill. The T35/S60 quick change feeder (QC) on display is designed for applications requiring quick changeover of materials and convenience of fast cleaning. The QC feeder allows for fast removal of the entire feeding module with screws in place for replacement with a second unit. Twin and single screw feeding modules are available.

The ActiFlow™ smart bulk solid activator offers an innovative method to reliably prevent bridging and rat-holing of cohesive bulk materials in stainless steel hoppers without internal hopper agitation. The smart flow aid applies gentle vibrations to the hopper wall, hereby carefully activating the contained material with the optimal amplitude and frequency, automatically adjusted by the controller based on bulk material flow. It is designed specifically to work with Coperion K-Tron's line of gravimetric loss-in-weight feeders.

The 2400 Series vacuum receivers provide a high-capacity sequencing system primarily used where larger conveying rates or long distances are required, in applications with one or multiple destinations. They are designed to high quality standards for pneumatically conveying powder, pellets and granular materials for most industries. Conveying rates range from 327 to 6,804 kg/h (720 to 15,000 lb/h). The 2415 pellet receiver will be on display at Chinaplas 2024.

Additionally, Coperion will display the preconfigured size S ProRate PLUS single screw feeder, equipped with a 2410 receiver for refill. This continuous gravimetric feeder is very robust and stands out for its good price-to-performance ratio. The ProRate PLUS line was designed as an especially economical solution for reliably feeding free-flowing bulk materials. Coperion has expanded the ProRate PLUS feeder line with a PLUS-MT twin screw feeder especially for feeding powders.

补料简便、稳定可靠的ProRate PLUS喂料机。
(图片：科倍隆楷创，瑞士)

The ProRate PLUS feeder line with refill solutions are simple, robust and reliable (Photo: Coperion K-Tron, Switzerland)



科倍隆、科倍隆楷创和Herbold Meckesheim参展
Chinaplas2024：2.1号展馆，F106号展位

Coperion, Coperion K-Tron and Herbold
Meckesheim at Chinaplas 2024:
Booth F 106 in Hall 2.1

► Coperion GmbH
Coperion K-Tron
www.coperion.com
► Herbold Meckesheim GmbH
www.herbold.com

重点关注交通出行和自动化

Focus on Mobility and Automation

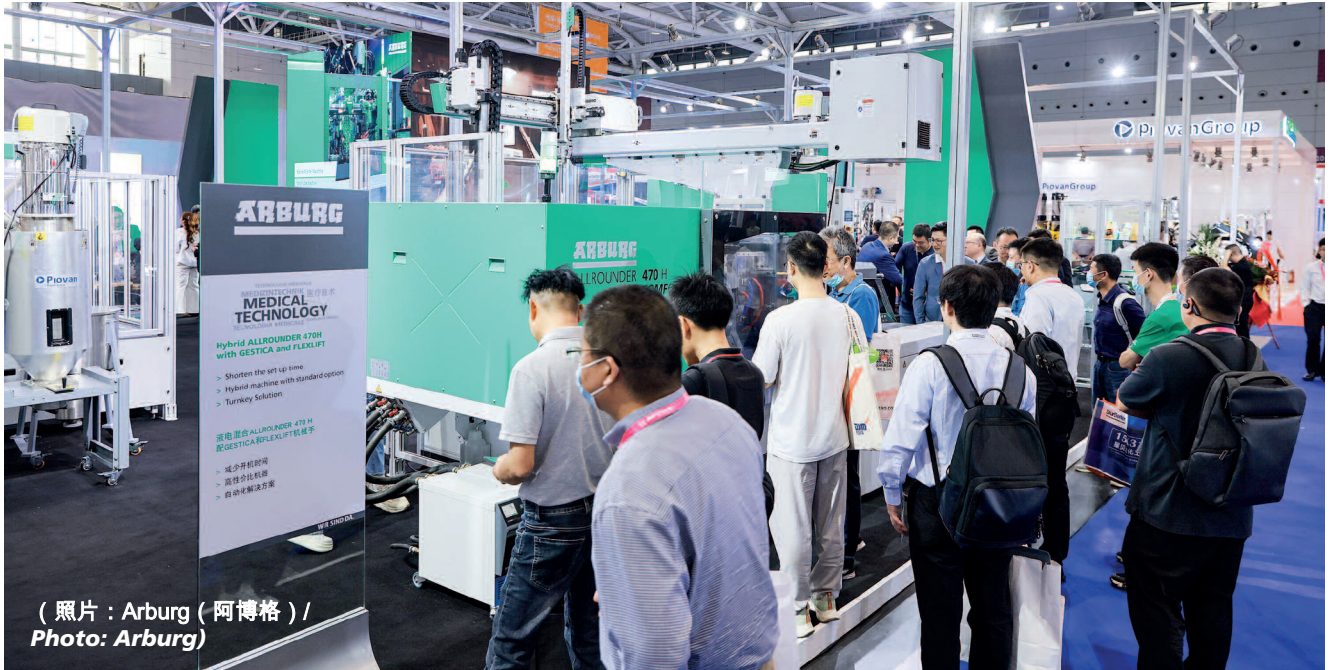

(照片: Arburg (阿博格) /
Photo: Arburg)

Arburg (阿博格) 将在计划于 2024 年 4 月 23 日至 26 日举办的中国国际橡塑展 (Chinaplas) 上展示自己作为高效塑料制品整体技术和系统合作伙伴的强大实力。公司将在位于 4.1 展厅的 D 42 展台上重点展示汽车和医疗领域内的各类广泛应用。三台 Allrounder 注塑机展示嵌件的全自动包胶注塑、液态硅橡胶 (LSR) 的加工以及复杂医疗部件的制造。除了注塑工艺之外, Arburg (阿博格) 还将展示增材制造和自动化产品和服务, 并在 arburgSOLUTIONworld 互动展区为专业访客提供全方位和个性化的咨询。

“在 2024 年的中国国际橡塑展上, 我们将首次在注塑机展馆, 这将进一步拉近我们与本地客户的距离。特别是在交通出行以及中高端电动汽车领域, 我们已在中国市场取得了成功。这两大领域也是我们本次展会关注的重点。”Arburg (阿博格) 中国区总经理佟朝强调说。“在 arburgSOLUTIONworld 中, 我们将通过展台集中展示我们在咨询领域内的专业能力。中国已建成了全球最大的 5G 网络, 数字化转型也是目前客户最关心的话题之一。我们的专家能够就相关问题作出专业解答, 并展示我们的数字化产品以及自动化解决方案和服务。”

“At Chinaplas 2024, we will be exhibiting in the same hall as the Asian injection molding machine manufacturers for the first time, bringing us even closer to our local customers. The mobili-

ty sector in particular, and especially electric vehicles in the mid and upper price segments, are successful in the Chinese market. This is why we have focused our exhibits on this area,” emphasises Zhao Tong, Managing Director of the Arburg organisations in China. “At arburgSOLUTIONworld, we are pooling our consulting expertise at the trade fair stand. China has built the world’s largest 5G network and digital transformation is currently a hot topic for our customers. Our experts will be on hand to answer questions and present our digital products as well as automation solutions and services.”

ty sector in particular, and especially electric vehicles in the mid and upper price segments, are successful in the Chinese market. This is why we have focused our exhibits on this area,” emphasises Zhao Tong, Managing Director of the Arburg organisations in China. “At arburgSOLUTIONworld, we are pooling our consulting expertise at the trade fair stand. China has built the world’s largest 5G network and digital transformation is currently a hot topic for our customers. Our experts will be on hand to answer questions and present our digital products as well as automation solutions and services.”

► Arburg GmbH + Co KG
P.O. Box 1109, 72286 Lossburg, Germany
www.arburg.com

SMART EXTRUSION

The only website collecting information about smart technologies of extrusion

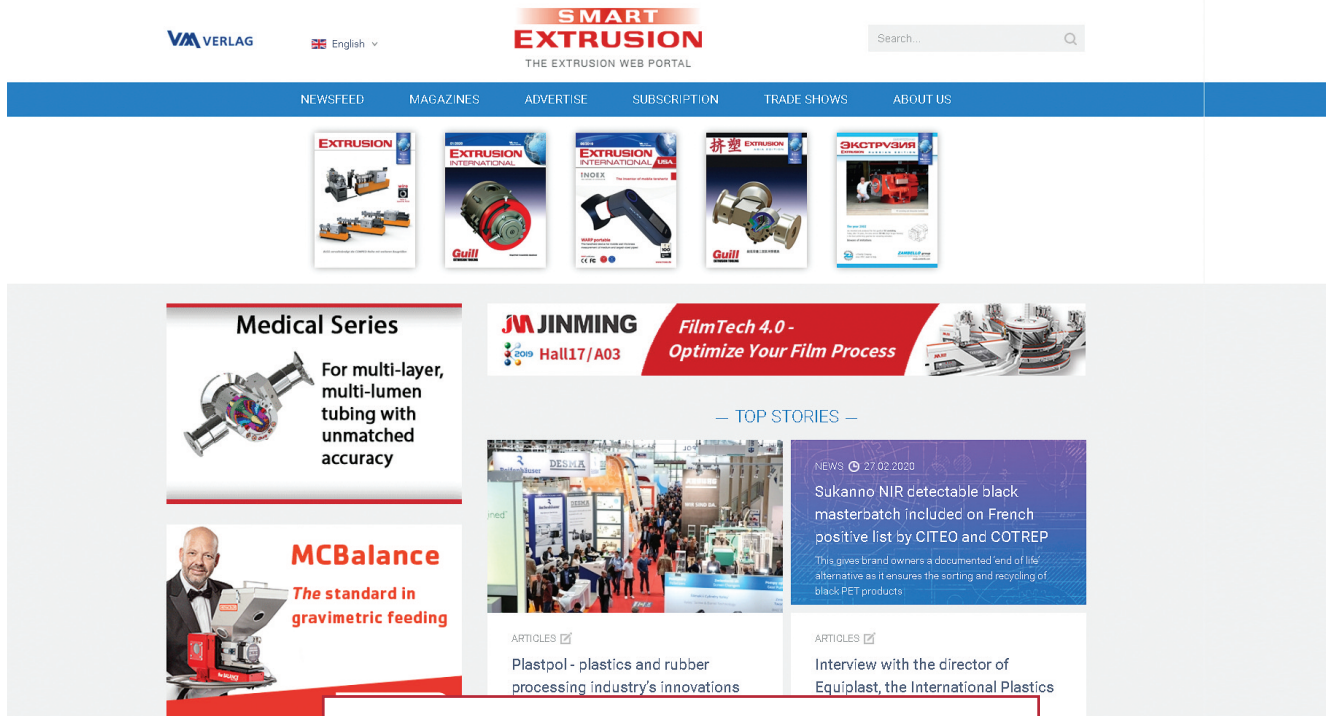

A SPECIALIZED WEB PORTAL

- ▶ News about relevant products and events
- ▶ Video clips demonstrating smart equipment in live action
- ▶ Detailed reviews of various smart technologies
- ▶ Latest magazines available for reading and downloading
- ▶ Case studies from processors
- ▶ Weekly e-mail newsletters
- ▶ English, German and Chinese

34 600 + average monthly visits

Geographic distribution of Smart_Extrusion readers, %

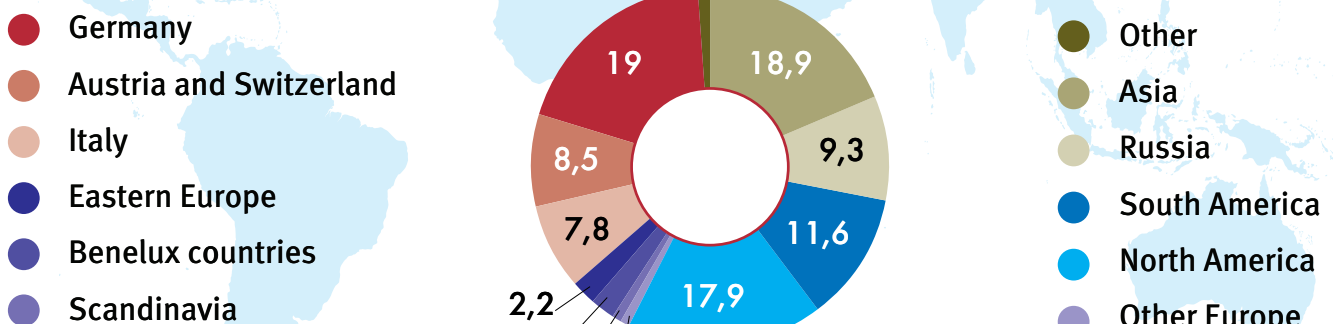

SMART EXTRUSION

**THE SPECIALIZED WEBPORTAL
ON EXTRUSION
FOR EVERY MODERN NEED**



VM Verlag GmbH
Cologne, Germany



www.smart-extrusion.com